



V02

# INSTALLATION & OPERATION & MAINTENANCE MANUAL OF ENERGY STORAGE SYSTEM(ESS) SMILE-S5/B5 SYSTEM



## **DISCLAIMER**

Copyright © AlphaESS Co., Ltd. 2022. All rights reserved.

No part of this document may be reproduced or transmitted in any form or by any means without prior written consent of AlphaESS Co., Ltd.

The material furnished in this document is believed to be accurate and reliable. The information and recommendations in this document do not constitute commitments or warranties in the form of assignments. The information in this document is subject to change without notice. You may refer to the AlphaCloud platform (<https://cloud.alphaess.com>) for the most updated version.

All company and brand products and service names are trademarks or registered trademarks of their respective holders.

## **COPYRIGHT STATEMENT**

This manual is under the copyright of Alpha ESS Co., Ltd. with all rights reserved. Please keep the manual properly and operate in strict accordance with all safety and operating instructions in this manual. Please do not operate the product before reading through the manual.

# CONTENT

<b>DISCLAIMER</b> .....	<b>1</b>
<b>COPYRIGHT STATEMENT</b> .....	<b>2</b>
<b>CONTENT</b> .....	<b>3</b>
<b>1. INTRODUCTION</b> .....	<b>7</b>
<b>1.1. Content and Structure of this Document</b> .....	<b>7</b>
<b>1.2. Target Group</b> .....	<b>7</b>
<b>1.3. Levels of Warning Messages</b> .....	<b>8</b>
<b>1.4. Definition of Abbreviations and Nouns</b> .....	<b>9</b>
<b>2. Safety</b> .....	<b>10</b>
<b>2.1. Intended Use</b> .....	<b>10</b>
<b>2.2. Safety Instructions for Battery Pack</b> .....	<b>11</b>
2.2.1. General Safety Precautions.....	11
2.2.2. Response to Emergency Situations .....	11
<b>2.3. Important Safety Instructions</b> .....	<b>12</b>
<b>2.4. Symbols on the label</b> .....	<b>15</b>
<b>3. Product Introduction and Application Scenarios</b> .....	<b>17</b>
<b>3.1. Nomenclature introduction</b> .....	<b>17</b>
<b>3.2. Product Description</b> .....	<b>17</b>
3.2.1. Inverter Introduction .....	17
<b>3.3. Application Scenarios</b> .....	<b>22</b>
<b>4. Storage and Transport</b> .....	<b>23</b>
<b>4.1. Storage</b> .....	<b>23</b>
<b>4.2. Transport</b> .....	<b>24</b>



<b>5. Mounting .....</b>	<b>25</b>
<b>5.1. Checking the Outer Packing.....</b>	<b>25</b>
<b>5.2. Scope of Delivery .....</b>	<b>25</b>
<b>5.3. Requirements for Mounting.....</b>	<b>27</b>
5.3.1. Basic Requirements .....	27
5.3.2. Mounting Environment Requirements.....	27
5.3.3. Mounting Structure Requirements.....	27
5.3.4. Mounting Angle and Stack Requirement.....	28
5.3.5. Mounting Space Requirements .....	28
<b>5.4. Preparing Tools and Instruments .....</b>	<b>29</b>
<b>5.5. Mounting the Product.....</b>	<b>30</b>
5.5.1. Mounting the Product.....	30
5.5.2. Mounting more battery packs .....	31
5.5.3. Mounting the WiFi Module .....	32
<b>6. Electrical Connection.....</b>	<b>33</b>
<b>6.1. Requirements for Connection .....</b>	<b>34</b>
<b>6.2. Connecting Additional Grounding.....</b>	<b>35</b>
<b>6.3. AC Connection .....</b>	<b>35</b>
6.3.1. Conditions for the AC Connection.....	35
6.3.2. Selecting Suitable AC Circuit Breaker .....	36
6.3.3. Grid and Backup Connection.....	37
<b>6.4. CT Connection &amp; Electricity Meter Connection .....</b>	<b>39</b>
6.4.1. CT Connection .....	39
6.4.2. Meter Connection .....	40
6.4.3. Configuring the Meter .....	42
<b>6.5. Communication Connection.....</b>	<b>45</b>
6.5.1. AUX/LAN/PV-CT/DRM、RRCR/GRID-CT、Meter/RS485/BMS Connection.....	45
<b>6.6. PV Connection.....</b>	<b>46</b>
<b>6.7. Electrical Connection of Expandable Battery Packs .....</b>	<b>47</b>
<b>6.8. Mounting the Battery Cover and Cable Cover .....</b>	<b>49</b>

<b>7. Installer Account Register and Install New System.....</b>	<b>51</b>
<b>7.1. Registration on APP .....</b>	<b>51</b>
7.1.1. Download and Install APP.....	51
7.1.2. Register as Installer Account.....	51
7.1.3. Overview of Functions for Installer Account.....	52
7.1.4. Install New System.....	53
<b>7.2. Register on AlphaCloud .....</b>	<b>55</b>
7.2.1. Register as Installer Account.....	55
7.2.2. Install New System.....	56
<b>8. Powering On and Off the product.....</b>	<b>58</b>
<b>8.1. Powering on the Product.....</b>	<b>58</b>
<b>8.2. Powering off the Product .....</b>	<b>58</b>
<b>9. COMMISSIONING .....</b>	<b>59</b>
<b>9.1. Checking Before Power-On .....</b>	<b>59</b>
<b>9.2. Powering on the Product.....</b>	<b>59</b>
<b>9.3. WiFi Module Configuration and Parameter Settings.....</b>	<b>60</b>
9.3.1. WiFi Configuration.....	60
9.3.2. Direct Commissioning on WiFi configuration .....	65
9.3.3. Check the basic parameters.....	67
<b>9.4. Installing New System and Settings on the APP .....</b>	<b>68</b>
9.4.1. Download and Install the APP.....	68
9.4.2. Register as an Installer.....	68
9.4.3. Install New System.....	69
<b>9.5. Check the Running State .....</b>	<b>70</b>
9.5.1. Check the Charging Function of the Product.....	70
9.5.2. Check the PV Generation and Discharging Function of the Product.....	72
9.5.3. Check the UPS State of the Product.....	73
<b>9.6. Instruct the End User to Install the APP .....</b>	<b>73</b>
<b>10. Maintenance and Troubleshooting .....</b>	<b>74</b>
<b>10.1. Routine Maintenance.....</b>	<b>74</b>



---

<b>10.2. Troubleshooting.....</b>	<b>75</b>
10.2.1. Inverter Error Troubleshooting .....	75
10.2.2. Battery Protection Description.....	81
10.2.3. Battery Error Description.....	82
<b>11. Uninstallation &amp; Return .....</b>	<b>83</b>
<b>11.1. Removing the Product .....</b>	<b>83</b>
<b>11.2. Packing the Product .....</b>	<b>83</b>
<b>11.3. Disposing of the Product.....</b>	<b>83</b>
<b>12. Specification .....</b>	<b>84</b>
<b>12.1. General overview.....</b>	<b>84</b>
<b>12.1. Datasheet of SMILE-S5/B5.....</b>	<b>85</b>
<b>12.2. Datasheet of Battery SMILE-5P .....</b>	<b>87</b>
<b>13. Appendix 1: System Overview.....</b>	<b>88</b>
<b>14. Appendix 2: Regional Application Standard .....</b>	<b>94</b>
<b>15. Appendix 3: Nomenclature of Model .....</b>	<b>94</b>
<b>16. Appendix 4: Earth Fault.....</b>	<b>95</b>

## 1. INTRODUCTION

### 1.1. Content and Structure of this Document

This document is valid for product of SMILE-S5/B5 and expandable battery pack SMILE-BAT-5P.

This document describes the mounting, installation, commissioning, configuration, operation, troubleshooting and decommissioning of the product as well as the operation of the product user interface.

Observe all documentation that accompanies the product, keep them in a convenient place and available at all times.

Illustrations in this document are reduced to the essential information and may deviate from the real product.

### 1.2. Target Group

This document is intended for qualified persons and end users. Only qualified persons are allowed to perform the operations marked with a warning symbol. Tasks that do not require any particular qualifications are not be marked and can be performed by the end user.





Qualified persons must have the following skills:

- Knowledge of how an inverter works and operates.
- Training in how to-deal with the dangers and risks associated with installing and using electrical devices, batteries, inverters and systems.
- Training in the installation and commissioning of electrical devices, inverters and systems.
- Knowledge of the applicable standards and directives.
- Knowledge of compliance with this document, including all safety precautions.
- Knowledge of compliance with the documents of the battery manufacturer, including all safety precautions.



### 1.3. Levels of Warning Messages

The following levels of warning messages may occur when handling the product

 <b>DANGER</b> DANGER indicates a hazardous situation which, if not avoided, will result in death or serious injury.
 <b>WARNING</b> WARNING indicates a hazardous situation which, if not avoided, could result in death or serious injury.
 <b>CAUTION</b> CAUTION indicates a hazardous situation which, if not avoided, could result in minor or moderate injury.
 <b>NOTICE</b> NOTICE indicates a situation which, if not avoided, can result in property damage.
INFORMATION provides tips which are valuable for the optimal installation and operation of the product.

## 1.4. Definition of Abbreviations and Nouns

### A

AC alternating current

APP application

AUX auxiliary

### B

BAT battery

BMS battery management system

### D

DC direct current

### E

EMS energy management system

### I

INV inverter

### P

PV photovoltaic

## 2. Safety

### 2.1. Intended Use

The inverter, battery packs and the energy meters make up a system for optimization of self-consumption for a household. The inverter is equipped with two MPP trackers and converts the direct current from the PV array into grid-compliant single-phase current and feeds it into the utility grid. The Battery pack is used for the intermediate storage of the energy.

The product is suitable for indoor and outdoor installation.

SMILE-S5 must only be operated with PV arrays of protection class II in accordance with IEC 61730, application class A. The PV modules must be compatible with this product.

PV modules with a high capacity to ground must only be used if their coupling capacity does not exceed 1.0  $\mu\text{F}$ .

All components must operate in a scenario suitable for their operation.

Be sure to use this product only in accordance with the information provided in the enclosed documentation and with locally applicable standards and directives. Any other operation may cause personal injury or property damage.

Alterations to the product, e.g. changes or modifications, are only permitted with the express written permission of AlphaESS. Unauthorized alterations will void guarantee and warranty claims. AlphaESS shall not be held liable for any damage caused by such changes.

Any use of the product other than that described in the Intended Use section does not qualify as appropriate.

The enclosed documentation is an integral part of this product. Keep the documentation in a convenient place for future reference and observe all instructions contained therein.

The type label must remain permanently attached to the product.

## 2.2. Safety Instructions for Battery Pack

### 2.2.1. General Safety Precautions

- Overvoltage or wrong wiring can damage the battery pack and cause deflagration, which can be extremely dangerous.
- All types of breakdown of the battery may lead to a leakage of electrolyte or flammable gas.
- Battery pack is not user serviceable. High voltage is present in the device.
- Read the label with Warning Symbols and Precautions, which is on the right side of the battery pack.
- Do not connect any AC conductors or PV conductors which should be only connected to the inverter directly to the battery pack.
- Do not charge or discharge damaged battery.
- Do not damage the battery pack in such ways as dropping, deforming, impacting, cutting or penetrating with a sharp object. It may cause a leakage of electrolyte or fire.
- Do not expose battery to open flame.

### 2.2.2. Response to Emergency Situations

The battery pack comprises multiple batteries that are designed to prevent hazards resulting from failures. However, AlphaESS cannot guarantee their absolute safety.

- If the user happens to be exposed to internal materials of battery cell due to damage on the outer casing the following actions are recommended.

1. Inhalation: Leave the contaminated area immediately and seek medical attention.

2. Eye contact: Rinse eyes with running water for 15 minutes and seek medical attention.

3. Contact with skin: Wash the contacted area with soap thoroughly and seek medical attention.

4. Ingestion: Induce vomiting and seek medical attention.

If a fire breaks out in the place where the battery pack is installed, perform the following countermeasures:

- Fire extinguishing media

1. Respirator is not required during normal operations.

2. Use FM-200 or CO<sup>2</sup> extinguisher for battery fire.

3. Use an ABC fire extinguisher, if the fire is not from battery and not spread to it yet.

- Firefighting instructions
  1. If fire occurs when charging batteries, if it is safe to do so, disconnect the battery pack circuit breaker to shut off the power to charge.
  2. If the battery pack is not on fire yet, extinguish the fire before the battery pack catches fire.
  3. If the battery pack is on fire, do not try to extinguish but evacuate people immediately.

**WARNING**

There may be a possible explosion when batteries are heated above 150°C. When the battery pack is burning, it leaks poisonous gases. Do not approach.

- Effective ways to deal with accidents
  1. On land: Place damaged battery into a segregated place and call local fire department or service engineer.
  2. In water: Stay out of the water and don't touch anything if any part of the battery, inverter, or wiring is submerged.
  3. Do not use submerged battery again and contact the service engineer.

### 2.3. Important Safety Instructions

**DANGER****Danger to life due to electric shock when live components or cables are touched.**

High voltage are present in the conductive components or cables of the product. Touching live parts and cables results in death or lethal injuries due to electric shock.

- Do not touch non-insulated parts or cables.
- Disconnect the product from voltage sources and make sure it cannot be reconnected before working on the inverter or the battery pack.
- After disconnection, wait for 5 minutes until the capacitors have discharged.
- Do not open the product
- Wear suitable personal protective equipment for all work on the product.

 **WARNING****Risk of chemical burns from electrolyte or toxic gases.**

During normal operation, no electrolyte can leak from the battery pack and no toxic gases can form. Despite careful construction, if the battery pack is damaged or a fault occurs, it is possible that electrolyte may be leaked or toxic gases may form.

- Store the battery pack in a cool and dry place.
- Do not drop the battery pack or damage it with sharp objects.
- Only set the battery pack down on its back or its bottom.
- Do not install or operate the battery pack in potentially explosive atmosphere or areas of high humidity.
- If moisture has penetrated the battery pack (e.g. due to a damaged housing), do not install or operate the battery pack.
- In case of contact with electrolyte, rinse the affected areas immediately with water and consult a doctor without delay.

 **CAUTION****Risk of burns due to hot heatsink and housing.**

The heatsink and housing can get hot during operation.  
During operation, do not touch any parts other than the cover of the inverter.

 **NOTICE****Damage to the inverter due to electrostatic discharge.**

- Touching electronic components can cause damage to or destroy the inverter through electrostatic discharge.
- Ground yourself before touching any component.

 **NOTICE****Damage due to cleaning agents.**

- The use of cleaning agents may cause damage to the product and its components.
- Clean the product and all its components only with a cloth moistened with clear water.

 **DANGER****Danger to life due to electric shock when live components or DC cables are touched.**

When exposed to sunlight, the PV array generates high DC voltage which presents in the DC conductors. Touching the live DC cables can result in death or lethal injuries due to electric shock.

- Disconnect the inverter from voltage sources and make sure it cannot be reconnected before working on the device.
- Do not touch non-insulated parts or cables.
- Do not disconnect the DC connectors under load.
- Wear suitable personal protective equipment for all work on the inverter.

 **DANGER****Danger to life due to electric shock from touching an ungrounded PV module or array frame.**











- Touching ungrounded PV modules or array frames can result in death or lethal injuries due to electric shock.
- Connect and ground the frame of the PV modules, the array frame and the electrically conductive surfaces so that there is continuous conduction.
- Observe the applicable local regulations.

 **DANGER****Danger to life due to electric shock when touching live system components in case of a ground fault.**

If a ground fault occurs, parts of the system may still be live. Touching live parts and cables can result in death or lethal injuries due to electric shock.

- Disconnect the product from voltage sources and make sure it cannot be reconnected before working on the device.
- Touch the cables of the PV array and Battery system on the insulation only.
- Do not touch any parts of the substructure or frame of the PV array and Battery system.
- Do not connect PV strings and Battery system with ground faults to the inverter.













## 2.4. Symbols on the label

Symbol	Explanation
	Beware of a danger zone This symbol indicates that the product must be additionally grounded if additional grounding or equipotential bonding is required at the installation site.
	Beware of electrical voltage The product operates at high voltages.
	Beware of hot surface The product can get hot during operation.
	Danger to life due to high voltages in the inverter, observe a waiting time of 5 minutes. High voltages that can cause lethal electric shocks are present in the live components of the inverter. Prior to performing any work on the inverter, dis-connect it from all voltage sources as described in this document.
	WEEE designation Do not dispose of the inverter together with the household waste but in accordance with the disposal regulations for electronic waste applicable at the installation site.
	Observe the documentation
	CE marking The product complies with the requirements of the applicable EU directives.
	Certified safety The product is TUV-tested and complies with the requirements of the EU Equipment and Product Safety Act.
	RCM (Regulatory Compliance Mark) The product complies with the requirements of the applicable Australian standards.
	UKCA marking The product complies with the regulations of the applicable laws of England, Wales and Scotland.
	RoHS labeling The product complies with the requirements of the applicable EU directives.

Symbols on the type label of the inverter:



Symbols on the type label and warning label of the battery pack.

Symbol	Explanation
	Beware of a danger zone This symbol indicates that the product must be additionally grounded if additional grounding or equipotential bonding is required at the installation site.
	Risk of chemical burns
	Risk of explosion
	Observe the documentation
	Risk of electrolyte leakage
	CE marking The product complies with the requirements of the applicable EU directives.
	Refer to the instruction for operation
	Use eye protection
	Fire, naked light and smoking prohibited
	Install the product out of reach of children
	Do not dispose of the battery pack together with the household waste but in accordance with the locally applicable disposal regulations for batteries
	Recycling code
UN38.3	Marking for transport of dangerous goods The product passes the certifications of the UN38.3

### 3. Product Introduction and Application Scenarios

#### 3.1. Nomenclature introduction

## SMILE-S5/B5



Location	Name	Explain
1	SMILE	Residential system
2	S5/B5	S5: 5kW Single-phase hybrid inverter B5: 5kW Single-phase battery inverter

Complete designation	Designation in this document
SMILE-S5/B5	Energy storage system/System/Product
SMILE-BAT-5P	Battery





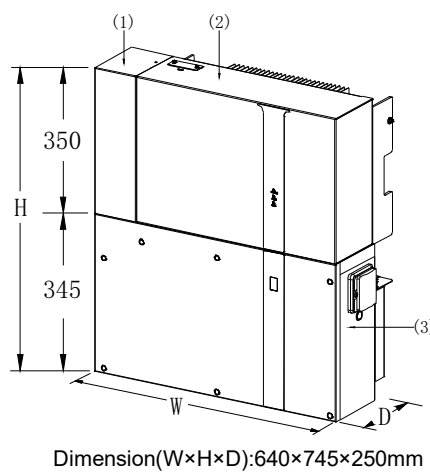



#### 3.2. Product Description

##### 3.2.1. Inverter Introduction



Object	Name	Explain
1	Cable Cover	Cover for the left wiring area
2	Inverter	Inverter part of the product
3	Battery	Battery part of the product

### Inverter LED Signals

LED	Status	Description
Normal		On: system is in working mode normally
		Flicker: system is in standby mode or self-checking process
		Off: system is in fault mode or off
Fault		Off: system is in working mode normally or off
		On: system is in fault mode
COM		On: network connection is normal
		Flicker: connecting to the server
		Off: system is not connected network

### Inverter light display during software downloading and upgrading process

During downloading the EMS and DSP program, the three green lights will flash from top to bottom. However, the upgrade process will be different. The three green lights will flash from bottom to top during upgrading DSP program, the three green lights will be shut off during upgrading EMS program, and at last the inverter will restart.

### Overview of the Product Connection Area

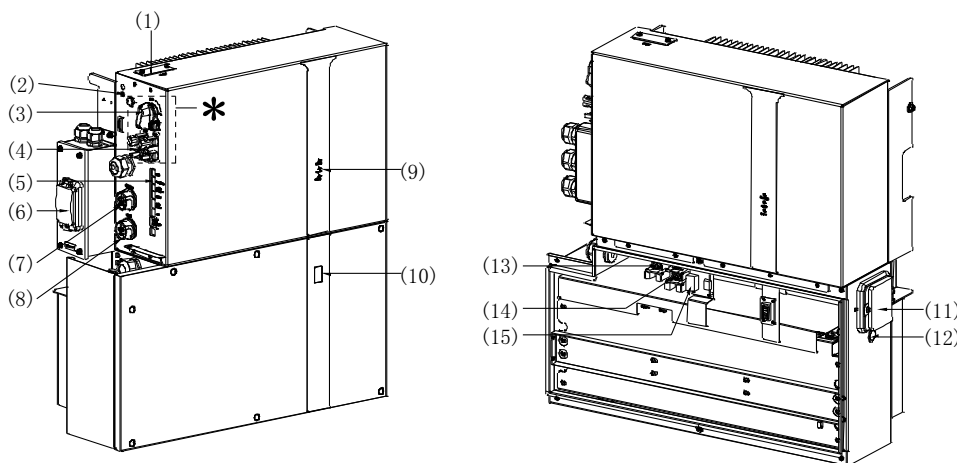

Position	Designation
1	Wi-Fi Port
2	Grounding
3	PV Switch***

4	PV Connectors***
5	Communication Ports ( CAN/RS485,BMS, LAN, Meter/Grid-CT, DRM**, PV-CT, AUX )
6	Battery Breaker* of the Inverter
7	Backup Connector
8	Grid Connector
9	Inverter LED Display
10	Battery LED Display
11	Battery Breaker of the Battery Pack *
12	Battery Power Button
13	Battery+ Power Connector
14	Battery- Power Connector
15	BMS COM Ports

\*All breakers of the product are switched off when shipped.

\*\*The DRM is only for regions with AS/NZW 4777.2 safety regulations.

\*\*\*For product B5, there are no PV switch and PV inputs.

The following table is about DRM interface definition, only for Australia.

Mode	Requirement
DRM0	Operate the disconnection device
DRM1	Do not consume power
DRM2	Do not consume at more than 50% of rate power
DRM3	Do not consume at more than 75% of rate power AND Source reactive power if capable
DRM4	Increase power consumption (subject to constraints from other active DRMs)
DRM5	Do not generate power
DRM6	Do not generate at more than 50% of rate power
DRM7	Do not generate at more than 75% of rate power AND Sink reactive power if capable
DRM8	Increase power generation (subject to constraints from other active DRMs)



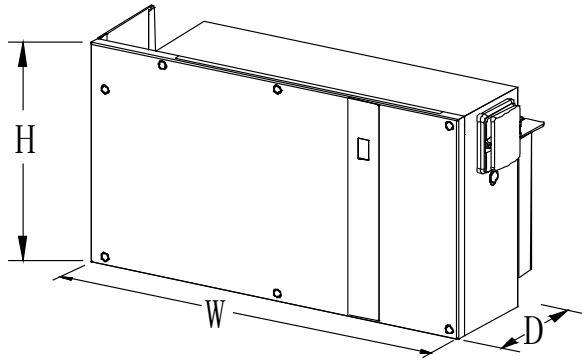



## Battery Introduction

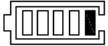

Dimension(W×H×D):640×345×250mm

Different colors of inner grids of the battery LED display represent different states: green for SOC state, red for error state.

The LED indicators provide information about the SOC operational status of the battery pack.

Item	SOC Status	Description
SOC Instruction		SOC < 5%
		5% = < SOC < 25%
		25% = < SOC < 50%
		50% = < SOC < 75%
		75% = < SOC < 95%
		SOC > 95%
LED Outer Ring Light Flicker Status		Upgrading: outer ring of the battery display is keeping solid green Working: green light flashes every 10s Standby: green light flashes every 1s Protection: green light flashes every 3s Error: red light flashes every 3s

**Overview of the Battery Pack Connection Area**

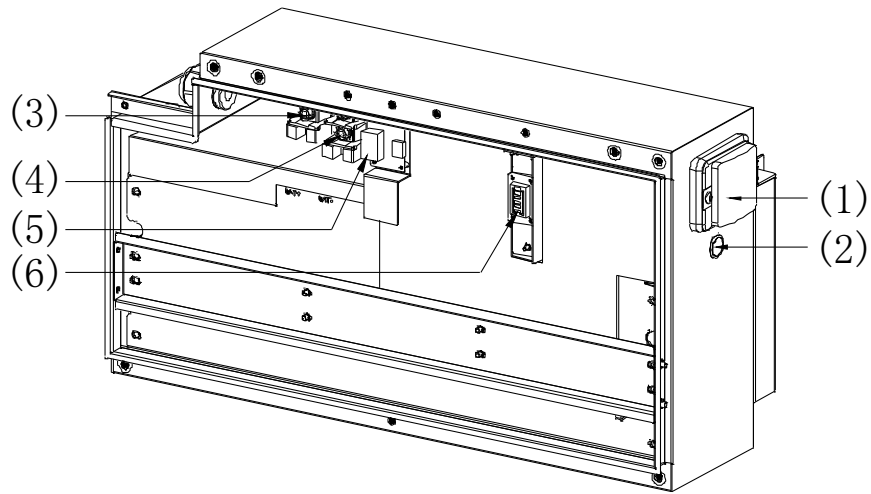

Position	Designation
1	Battery Breaker of the Battery Pack*
2	Battery Power Button
3	Battery+ Power Connector
4	Battery- Power Connector
5	BMS COM Ports
6	Battery LED Display

\*The breaker of the battery pack is switched off when shipped.



### 3.3. Application Scenarios

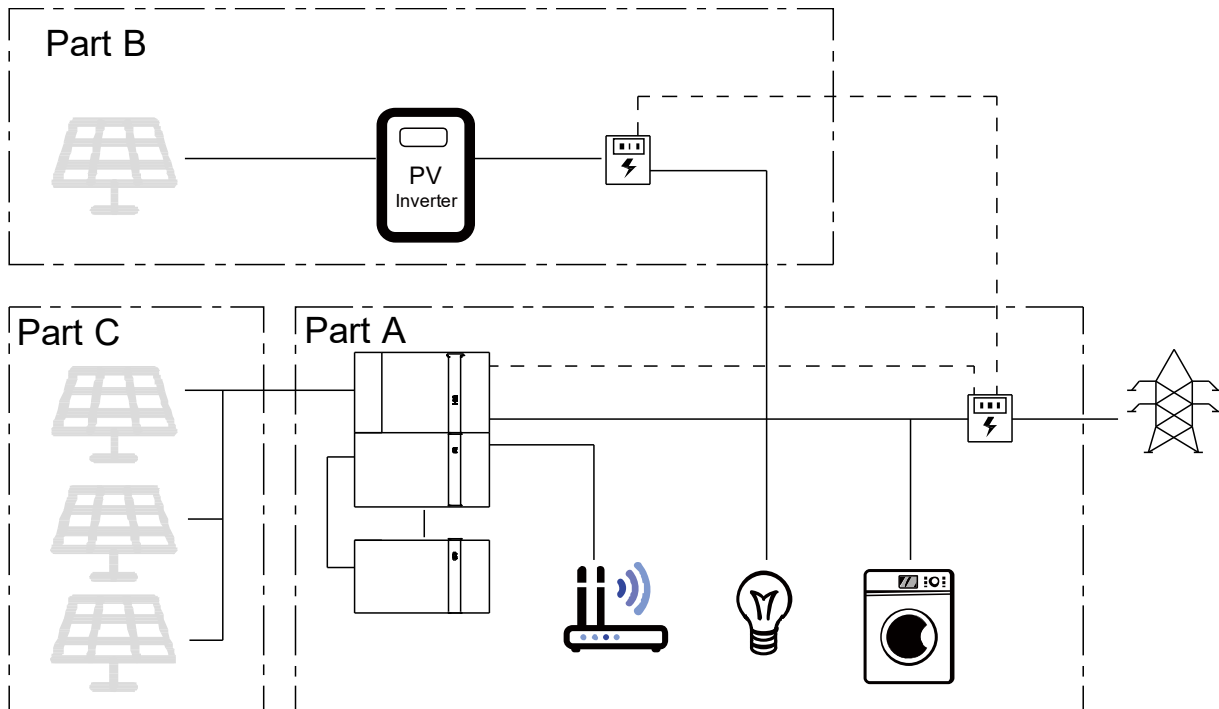

- PART A+PART C : DC-coupled Storage System
- PART A+PART B : AC-coupled Storage System
- PART A+PART B+ PART C : Hybrid-coupled Storage System

## 4. Storage and Transport

### 4.1. Storage

The following requirements should be met if the product is not put into use directly:

1. Don't unpack the product.
2. The product should be stored in a clean and dry place and be protected from dust and water vapor corrosion.
3. Place product according to the signs on the packing case during storage

A maximum of two layers can be stacked. To avoid personal injury or device damage, stack products with caution to prevent them from falling over.

4. Store the product out of reach of children and animals.
5. Handle product with caution to avoid damage.
6. The storage environment requirements are as follows:
  - Ambient temperature: -10~55°C, recommended storage temperature: 15~30°C
  - Relative humidity: 15%~ 85%
  - Place products in a place that is away from corrosive organic solvents and gases.
  - Keep products away from direct sunlight.
  - Keep products at least 2 meters away from heat sources.
7. The product in storage must be disconnected from external devices. The indicators (if any) on the products should be off.
8. Products should be delivered based on the "first in, first out" rule.
9. The warehouse keeper should collect battery storage information every month and periodically report the battery inventory information to the planning department. The batteries that have been stored for nearly 6 months should be recharged timely.
10. If a lithium battery is stored for a long time, capacity loss may occur. After a lithium battery is stored for 12 months in the recommended storage temperature, the irreversible capacity loss rate is 3%~10%. It is recommended that batteries not be stored for a long period. If the batteries need to be stored for more than 6 months, they

should be recharged every 6 months at least, and must be recharged to at least 50% of the SOC.



## 4.2. Transport

During transportation, please follow these guidelines:

1. Priority to use the original packaging for transportation. If the original packaging is not available, put the product inside a suitable cardboard box and seal it properly.
2. Handle with care, choose the corresponding handling method according to the weight, and pay attention to safety.

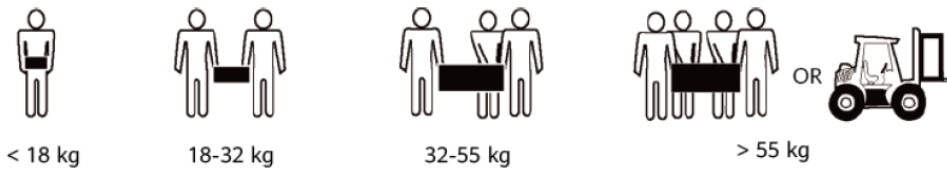

1. During transportation, please keep the packaging away from dangerous sources and take waterproof measures.
2. Please fix the packaging during transportation to prevent falling or mechanical impact.









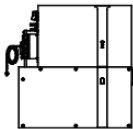
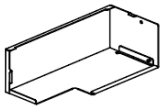

## 5. Mounting

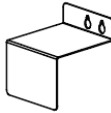
### 5.1. Checking the Outer Packing

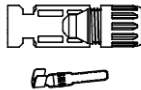
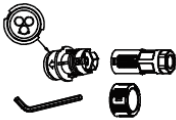
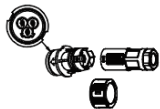
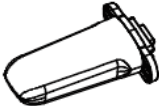
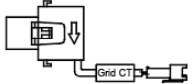
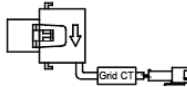
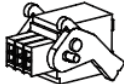

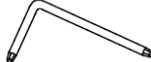



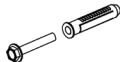
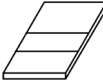

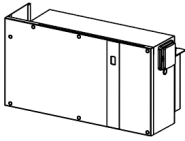

Before unpacking the product, check the outer packing for damage, such as holes and cracks. If any damage is found, do not unpack the product and contact your dealer as soon as possible.

### 5.2. Scope of Delivery

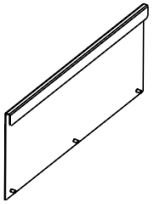
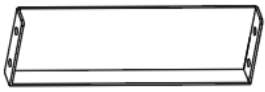
Check the scope of delivery for completeness and any externally visible damage. Contact your distributor if the scope of delivery is incomplete or damaged.

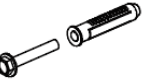
SMILES-S5/B5				
				
SMILE-S5/B5 (X1)	Cable Cover (X1)	Holder for Cable Cover (X1)	Cable Cover of the Battery Breaker (X1)	PV + Connector (X2)*
				
PV - Connector (X2)*	Grid Connector (X1)	Backup Connector (X1)	WiFi Module (X1)	Grid CT (X1)
				
PV CT (X1)	AUX Terminal Block (X1)	Fork Terminal Lug (X2)	T20 Screwdriver (X1)	Screw: M6*16 (X6), M4*12 (X5)
				
Screw M4 for cable cover (X1)	Silicon Plug (X8)	Wall Anchor ST6*55 (X6)	Documentation sheets	

\*Only for product SMILE-S5;

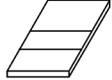
<b>SMILE-BAT-5P</b>			
			
SMILE-BAT-5P (X1)	Battery - Power Cable (X1)	Battery + Power Cable (X1)	Battery BMS Communication Cable (X1)
			
Side Plate of Battery (X1)	Expandable brackets (X2)	Screw: M6*16 (X4)	Wall Anchor ST6*55 (X6)
			
M4 Flange Nut (X11)	Silicon Plug (X8)	Fork Terminal Lug (X2)	Documentation sheets

### 5.3. Requirements for Mounting



#### WARNING

##### **Danger to life due to fire or explosion**

Despite careful construction, electrical devices can cause fires.

- Do not mount the product in areas containing highly flammable materials or gases.
- Do not mount the product in potentially explosive atmospheres.

#### 5.3.1. Basic Requirements

- The product is suitable for indoor and outdoor use.
- Do not install the product in a place where a person can easily touch it because its housing and heatsink are hot during operation.
- Do not mount the product in areas with flammable or explosive materials.
- Do not mount the product at a place within children's reach.
- Do not mount the product outdoors in salt areas because it will be corroded there and may cause fire. A salt area refers to the region within 500m from the coast or prone to sea breeze. The regions prone to sea breeze vary depending on weather conditions (such as typhoons and monsoons) or terrains (such as dams and hills).

#### 5.3.2. Mounting Environment Requirements

- The product must be mounted in a well-ventilated environment to ensure good heat dissipation.
- When mounted under direct sunlight, the power of the product may be derated due to additional temperature rise.
- Mount the product in a sheltered place or mount an awning over the product.
- The optimal temperature range for the battery pack to operate is from 15 to 30°C.
- Do not expose or place near water sources like downspouts or sprinklers.
- If the battery pack is mounted in the garage, then ensure that it is above the height of the vehicle bumper and/ or door.

#### 5.3.3. Mounting Structure Requirements

- The mounting structure where the product is mounted must be fireproof.
- Do not mount the product on flammable building materials.
- Ensure that the mounting surface is solid enough to bear the weight load.
- In residential areas, do not mount the product on drywalls or walls made of similar materials which have a weak sound insulation performance. Because the noise generated by the product is obvious.

### 5.3.4. Mounting Angle and Stack Requirement

The product should be mounted on the wall.

The installation angle requirement is as follow:

- Do not mount the product at forward tilted, side tilted, horizontal, or upside down positions.

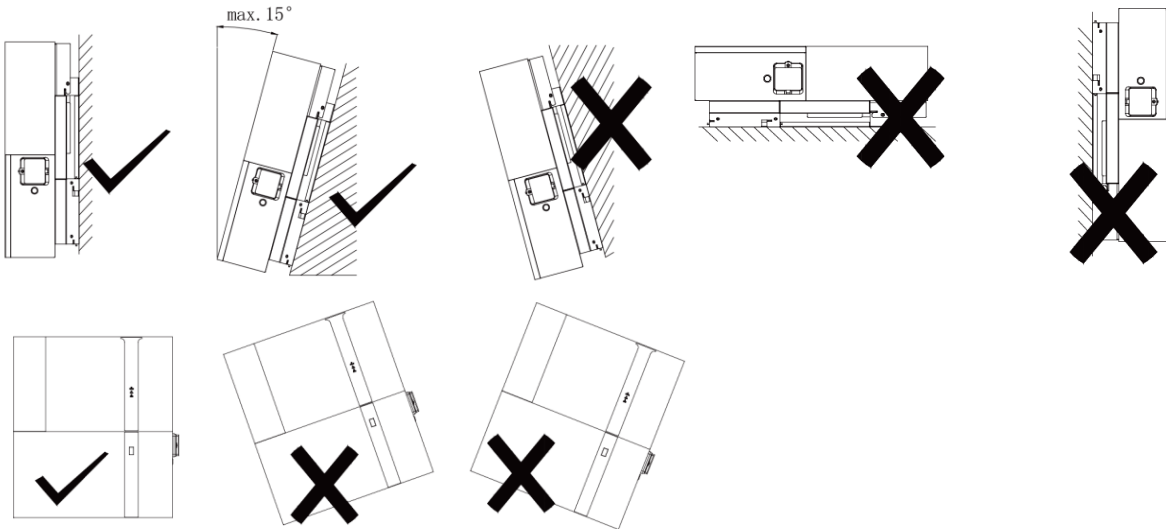





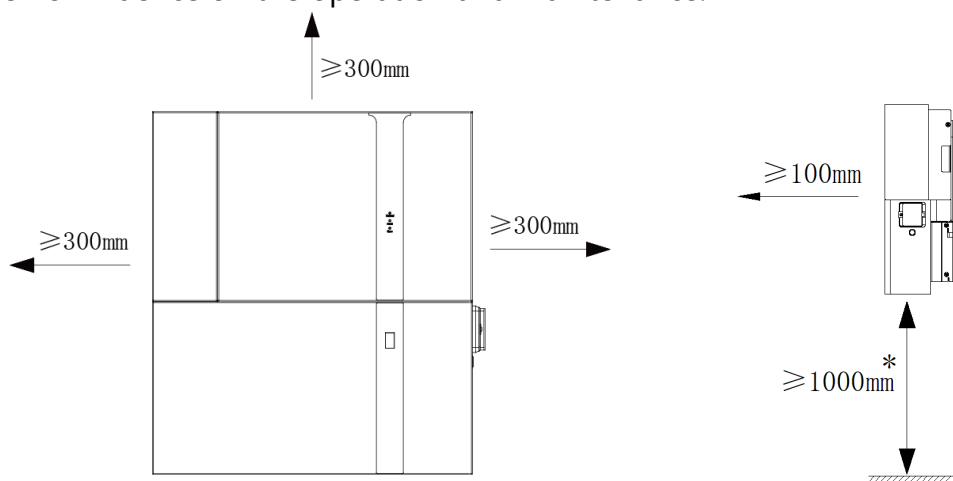





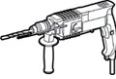



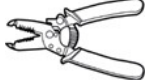







### 5.3.5. Mounting Space Requirements

- Reserve enough space around the product to ensure sufficient space for installation, maintenance and heat dissipation.
- The space below is a 'recommendation' only and a minimum of 150 ~ 200 mm off the ground is advisable to protect from submergence.
- The side space is a recommendation. Keep the space as short as you can if there is no influence on the operation and maintenance.

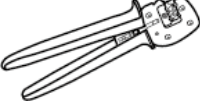

\*Depending on quantity of the expandable batteries

### 5.4. Preparing Tools and Instruments

Category	Tools and Instruments		
Installation			
	Hammer drill (with a $\Phi 10$ mm drill bit)	Torque socket wrench SW10	Multimeter (DC voltage range $\geq 1000$ V DC)
			
	Diagonal pliers	Wire stripper	T20 screwdriver, torque range: 0-5 N m) $L \geq 140$ mm
			
	Rubber mallet	Utility knife	Cable cutter
			
	Cord end terminal crimper	Measuring tape	Bubble or digital level
			
	Vacuum cleaner	Heat shrink tubing	Heat gun
			
Marker	Crimping tool (model: PV-CZM-19100)	Disassembly and Assembly Tool (model: PV-MS)	
Personal Protective Equipment			
	Safety gloves	Safety goggles	Anti-dust respirator
		N/A	N/A
Safety shoes			

## 5.5. Mounting the Product

### 5.5.1. Mounting the Product

Dimensions of wall bracket (mm)

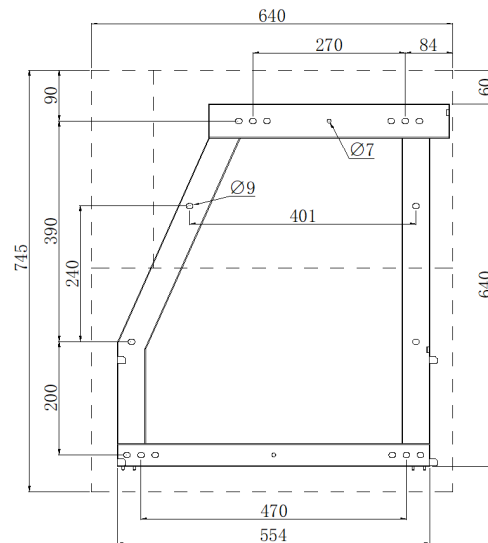

The steps to mount the product are listed below:

- a. Remove the wall bracket from the product, place it on the wall where the product will be mounted, and use a marker to locate the drill positions.
- b. Drill 6 holes on the wall with  $\Phi 10\text{mm}$  drill and insert the screw anchors into the drill holes.
- c. Attach the wall bracket to the wall and tighten the screws with the tool of SW10 hexagon sleeve.
- d. Hold the inverter by using the handles at two sides, and install the product on the wall bracket. This step should take two people to complete.
- e. Tighten the wall bracket and the product with screw M6\*16 (X6) (tool: T20 screwdriver, torque: 3.0 Nm).
- f. Loosen a few turns of the two screws, hang on the cable cover of the battery breaker, and then tighten the two screws.

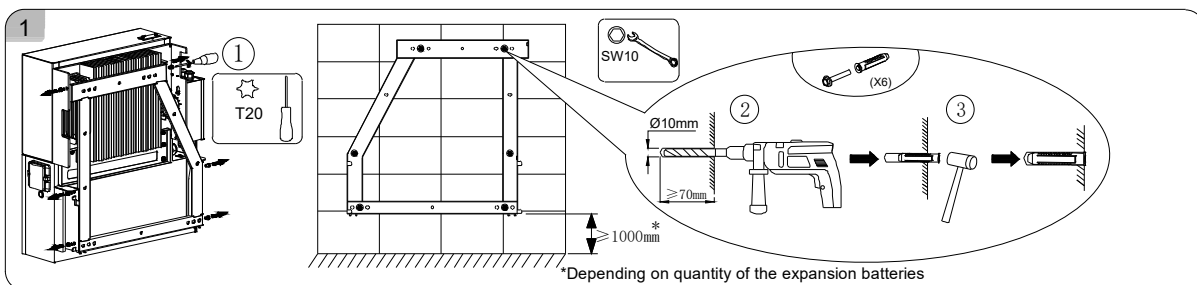

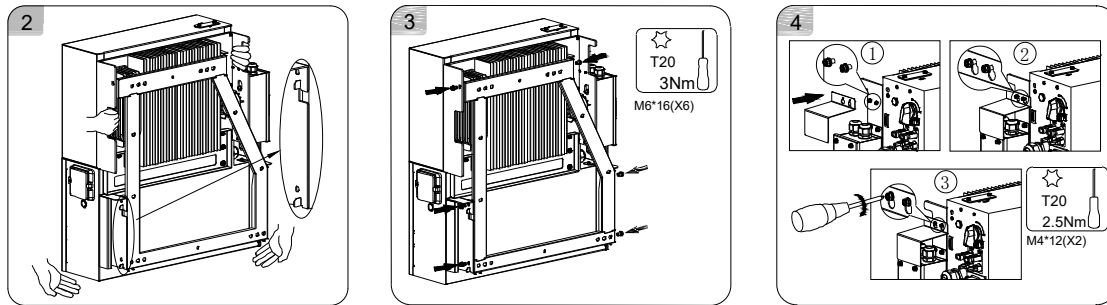

### 5.5.2. Mounting more battery packs

You can install up to five extra batteries.

The steps for mount more expandable battery packs is as below. Expansion wiring refer to chapter 6.7

**! NOTICE**

- If there are no expandable batteries to install, please ignore Chapter 6.3.2 and skip to 6.3.3.

- Remove the wall bracket from the battery pack.
- Take out the expandable brackets and the battery wall bracket, then fix them together with four M4 flange nuts (tools: SW7 sleeve, torque: 1.6 Nm).
- Use four M4 flange nuts to fix the wall bracket assembled in the step 1 to the wall bracket of SMILE-S5/B5.
- Mark the positions according to holes on the bracket and remove the assembled wall bracket.
- Drill 6 holes on the wall with  $\Phi 10\text{mm}$  drill and insert 6 screw anchors into the drill holes.
- Perform action step c.
- Attach the wall bracket to the wall and tighten the screws
- Hold the handles on both sides of the battery pack and install it on the wall bracket. This step should take two people to complete.
- Tighten the wall bracket and the expandable battery with screw M6\*16 (X4) (tool: T20 screwdriver, torque: 3.0 Nm).



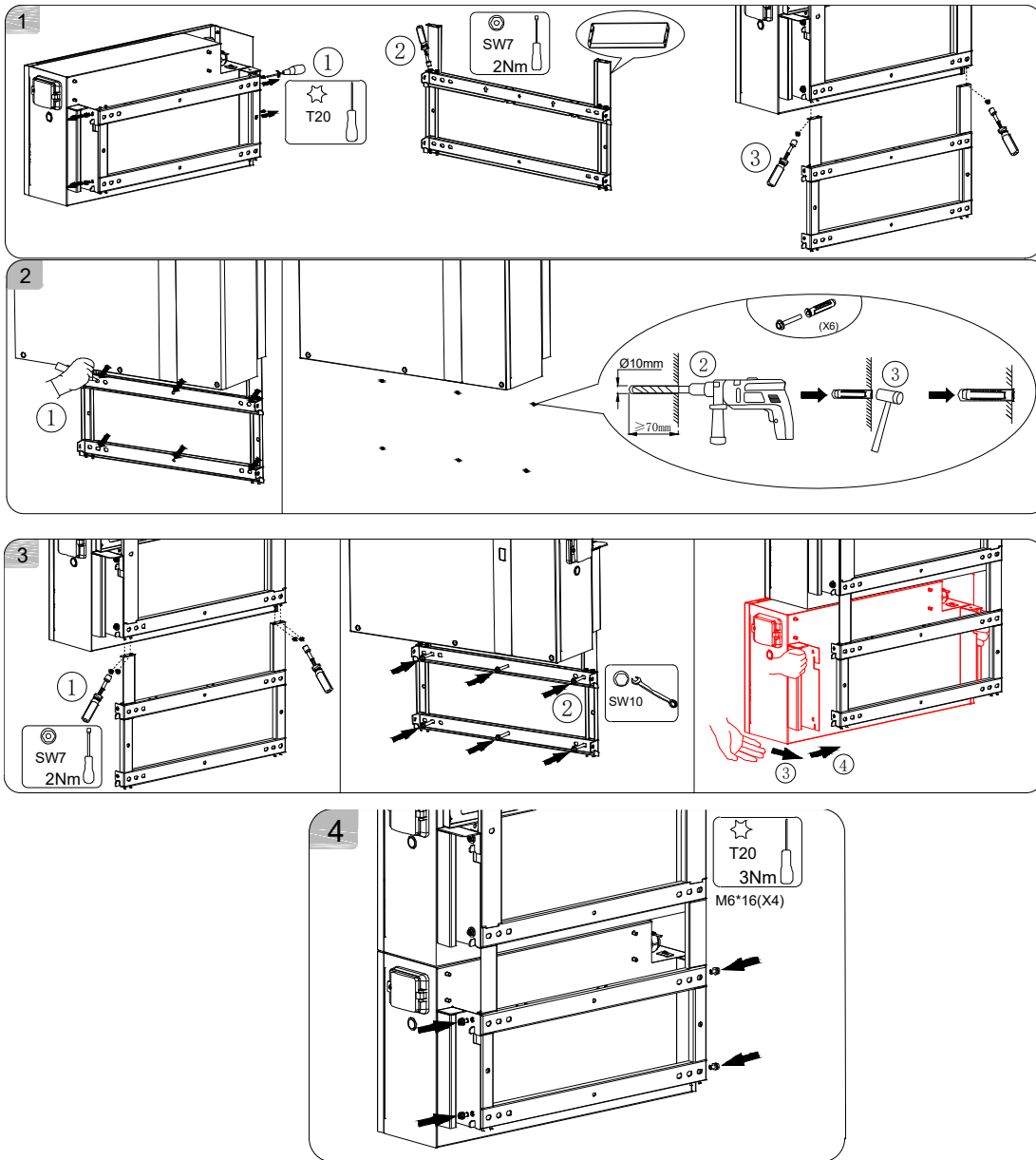

### 5.5.3. Mounting the WiFi Module

Remove the WiFi cover from the top of the inverter with Tool: 20 screwdriver.  
Tighten the WiFi module on the top.

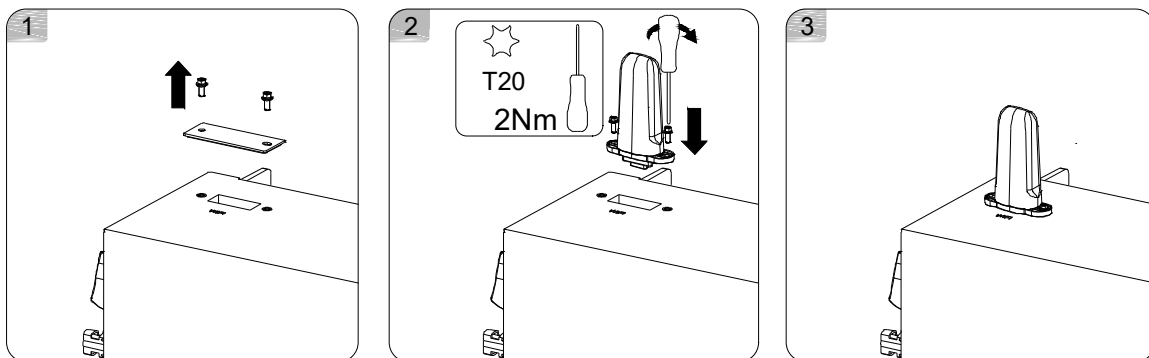

## 6. Electrical Connection

### Precautions

 **DANGER**

Before connecting cables, ensure that all breakers of the product and the battery pack and all the switches connected to product and the battery pack are set to OFF. Otherwise, the high voltage of the product may result in electric shocks.

 **WARNING**

- The device damage caused by incorrect cable connections is not covered under any warranty.
- Only certified electricians are allowed to connect cables.
- Operation personnel must wear proper PPE when connecting cables.

 **NOTICE**

The cable colors shown in the electrical connection diagrams provided in this chapter are for reference only.

Select cables in accordance with local cable specifications (green-and-yellow cables are only used for PE).

## 6.1. Requirements for Connection

No.	Cable	Type	Conductor Cross Section Area Range	Outer Diameter	Source
1	Expandable battery power cable	Standard PV cable in the industry (recommended type: PV1-F)	25 mm <sup>2</sup> or AWG4	N/A	Delivered with the battery pack
2	Expandable battery communication cable	Standard network cable in the industry (recommended type: Cat5e, UTP, UV-resistant for outdoor use)	0.12 ~ 0.2 mm <sup>2</sup> (AWG26~AWG24)	N/A	Delivered with the battery pack
3	PV power cable	Standard PV cable in the industry (recommended type: PV1-F)	4 ~ 6 mm <sup>2</sup>	5.5~9 mm	Purchased by the installer
4	CT communication cable	Standard network cable in the industry (recommended type: Cat5e, FTP, UV-resistant for outdoor use)	0.12 ~ 0.2 mm <sup>2</sup> (AWG26~AWG24)	N/A	Delivered with the Smile-S5/B5
5※ <sup>1</sup>	Signal cable	Standard network cable in the industry (recommended type: Cat5e, FTP, UV-resistant for outdoor use)	0.12 ~ 0.2 mm <sup>2</sup> (AWG26~AWG24)	4 ~ 6 mm	Purchased by the installer
6※ <sup>2</sup>	Signal cable	Multiple-core outdoor shielded twisted pair cable	0.1 ~ 1.3 mm <sup>2</sup>	4 ~ 6 mm	Purchased by the installer
7	Grid power cable	Three-core (L, N and PE) outdoor copper cable	4 ~ 6 mm <sup>2</sup>	8-14 mm	Purchased by the installer
8	Backup power cable	Three-core (L, N and PE) outdoor copper cable	2.5 ~ 6 mm <sup>2</sup>	8-14 mm	Purchased by the installer
9	PE cable	Single-core outdoor copper cable	6 ~ 10 mm <sup>2</sup>	N/A	Purchased by the installer

※1 For CAN/RS485, LAN, Meter, DRM communication connection with inverter.

※2 For AUX communication connection with inverter

## 6.2. Connecting Additional Grounding

**NOTE**

**Electric shock hazard**

Before doing electrical connection, please ensure the PV switch & all AC and BAT circuit breakers are switched off and cannot be reactivated.

An external grounding connection is provided at the left side of the product. Prepare M5 OT terminals, strip the grounding cable insulation, insert the stripped part of the grounding cable into the ring terminal lug and crimp using a crimping tool.

Connect the OT terminal with ground point using T20 screwdriver with 2.5Nm torque.

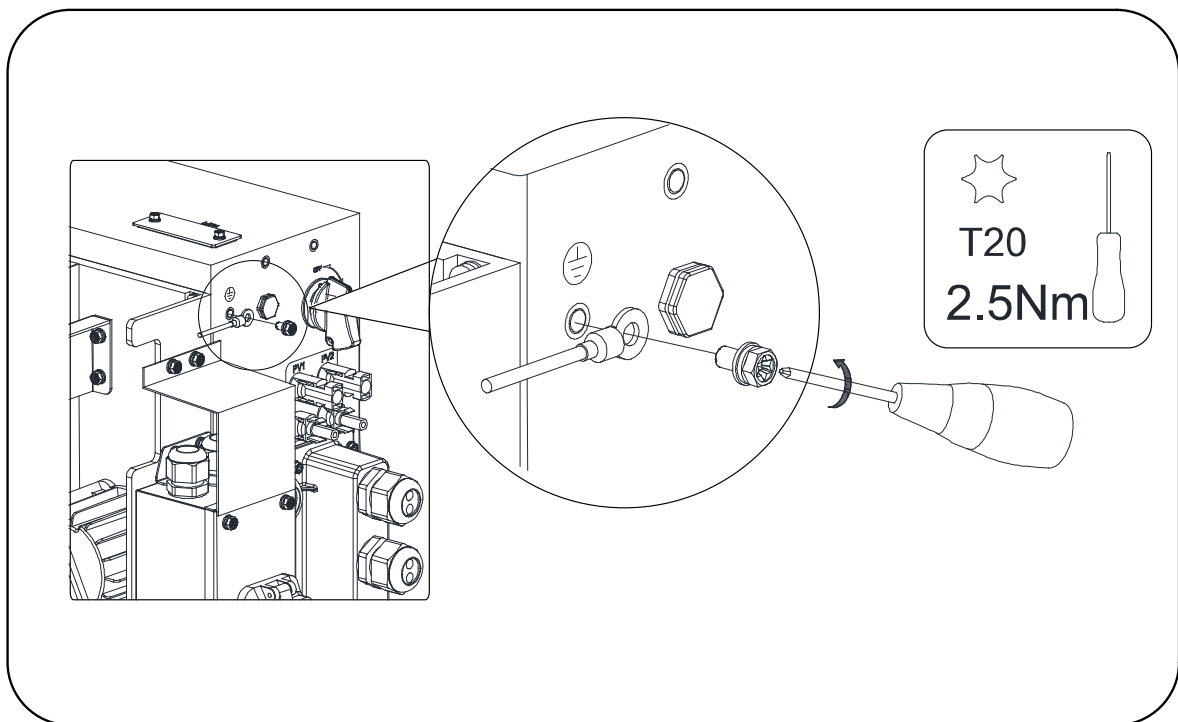

## 6.3. AC Connection

### 6.3.1. Conditions for the AC Connection

AC cable requirements as follows:

- Conductor type: copper wire
- External diameter: 8 mm to 14 mm
- AC Conductor cross-section recommendation: 6 mm<sup>2</sup>
- Insulation stripping length: 9 mm
- Sheath stripping length: 40 mm

 **NOTE****Residual-current monitoring unit:**

The inverter does not require an external residual-current device when operating. If local regulations require the use of a residual-current device, or hybrid-coupled storage system with big coupling capacity from the PV array and PV inverter, the following must be observed:

The inverter is compatible with type A residual-current device with a rated residual current of 100 mA or higher.

Each inverter in the system must be connected to the utility grid via a separate residual-current device

 **DANGER**

You must protect each inverter with an individual grid/backup circuit breaker in order to ensure that the inverter can be disconnected safely.

**6.3.2. Selecting Suitable AC Circuit Breaker**

The general requirements for the selection of circuit breakers are determined by standards and country specific provisions. In the following, generally applicable influencing factors to be considered when selecting a suitable circuit breaker are listed:

Factors influencing the ampacity of the cable: type of cable used, ambient temperature around the cable, type of cable routing, bundling of cables.

Other influences on dimensioning: loop impedance, mutual heating of circuit breakers, ambient temperature at the circuit breaker, selectivity, type of connected device.

If these factors are ignored, it increases the danger of the circuit breaker tripping under normal operating conditions.

Description	Max. Current	Breaker Type for SMILE-S5/B5
Grid Side	30.4A	32A
Backup Side	21.7A	32A

 **WARNING**

The maximum allowable AC circuit breaker specification for grid and backup side is 32A at the same time the copper conductor cross section for connection must be 6mm<sup>2</sup> when selecting a circuit breaker and copper conductor cross section, otherwise it increases the danger of the circuit breaker tripping under normal operating conditions.

### 6.3.3. Grid and Backup Connection

The steps for connecting the backup power cable as follows:

1. Disconnect the circuit breakers and secure it against reconnection.
2. Dismantle the AC cable by 40 mm.
3. Shorten L and N by 5 mm each, so that the grounding conductor is 5 mm longer. This ensures that the grounding conductor is the last to be pulled from the screw terminal in the event of tensile strain.
4. Strip the insulation of L, N and the grounding conductor 9 mm.
5. In the case of fine stranded wire L, N and PE are to be fitted with bootlace ferrules.
6. Disassemble the AC connector and connect the conductors to the AC connector.
7. Ensure that all conductors are securely connected to the AC connector, assemble the AC connector.
8. Plug the AC connector into the socket for the AC connection.

When doing so, align the AC connector so that the key on the inverter AC socket is inserted into the keyway on the AC connector bush insert.

Finally, turn the backup connector slightly clockwise until you hear a "click" sound.

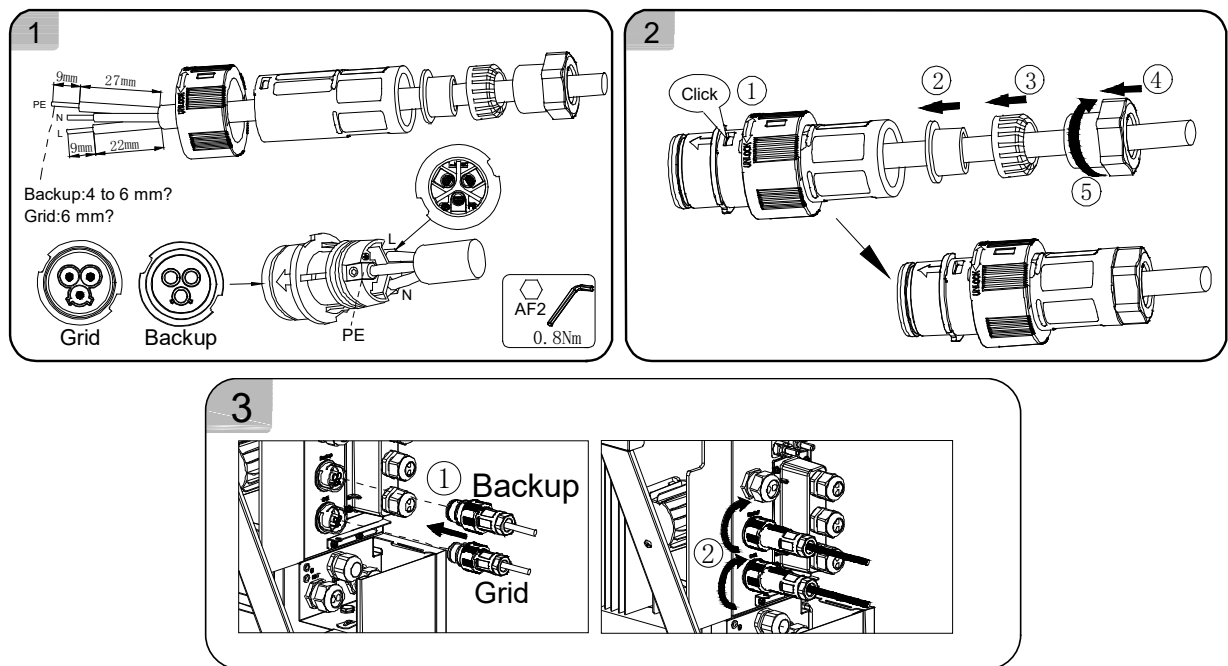

The connection of grid connector is similar to the above steps, please follow it. At last please secure the two AC cables to the housing with a cable tie.

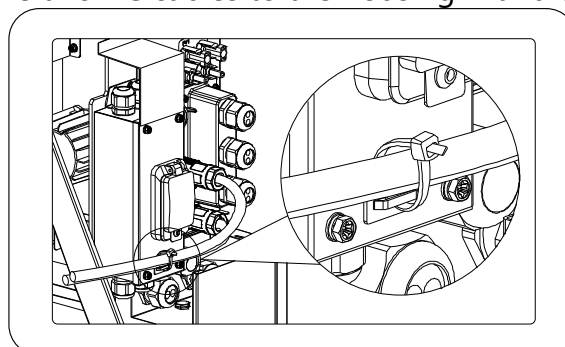

**!** NOTE

For Australia and New Zealand installation, the neutral cable of grid side and backup side must connect together, otherwise backup output function will not work.

PS: Follow-up steps for disassembling the AC connector:

To disassemble the AC connectors from the product.

- 1、 Unscrew the AC connector counterclockwise until it can't be rotated.
- 2、 Take out the removal tool from the inner side of the inverter cable cover and insert its head part into the slot of the AC connector until you hear a "click" sound.
- 3、 Unscrew the AC connector counterclockwise and unplug it.

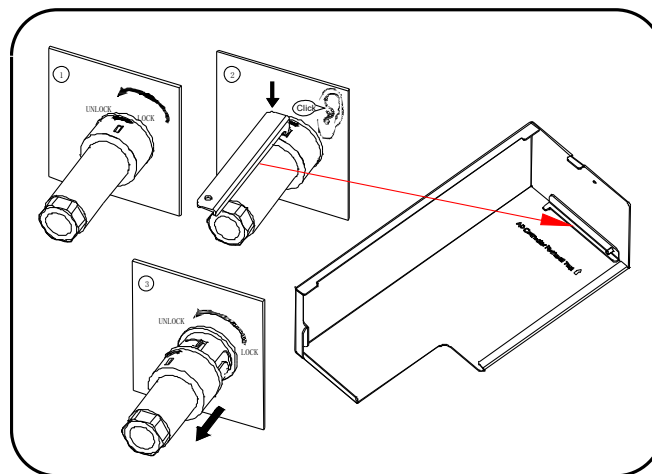
**!** NOTE

Regarding the situation of earth fault, please refer to Appendix 4.

### 6.4. CT Connection & Electricity Meter Connection

Item	Current	Scenarios
CT	100A	Grid-CT, PV-CT
DTSU666-3*230V 5(80)A	80A	Three phase meter (without CT)
DTSU666-3*230V 100A/40mA	100A	Three phase meter (with CT)
DTSU666-3*230V 250A/50mA	250A	Three phase meter (with CT)

#### 6.4.1. CT Connection

The CT cables for grid CT and PV CT have been installed with the product when shipped.

Please take out CT magnetic snaps from the package.

**Step 1:** Buckle the magnetic snap of the Grid CT on the house-service live cable.

The arrow on the magnetic snap of the Grid CT should point to the grid connection port of energy storage inverter.

**Step 2:** Buckle the magnetic snap of the PV CT on the live cable of the installed PV inverter. The arrow on the magnetic snap of the PV CT should point to the mains grid.

**Step 3:** Connect the CT cables to the Grid CT and PV CT respectively.

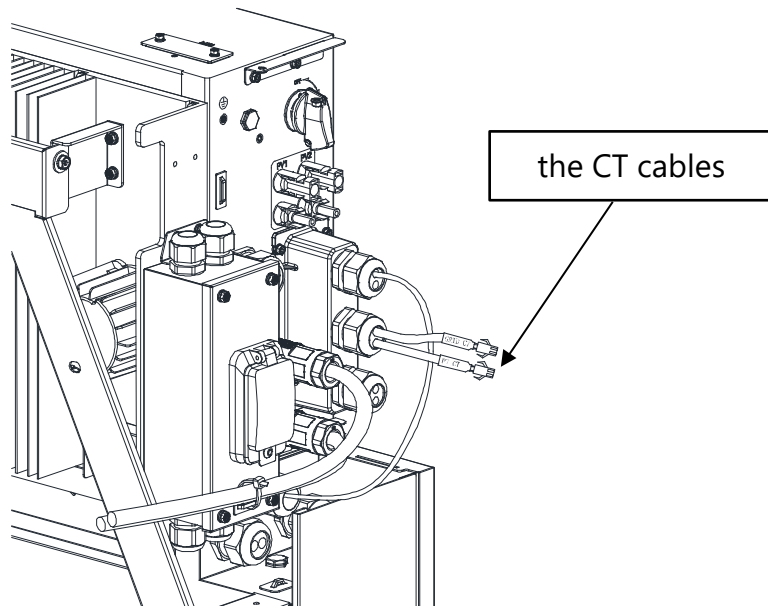

**! NOTE**

The CT cable marked Grid CT must connect to the Grid CT, and the CT cable marked PV CT must connect to the PV CT.



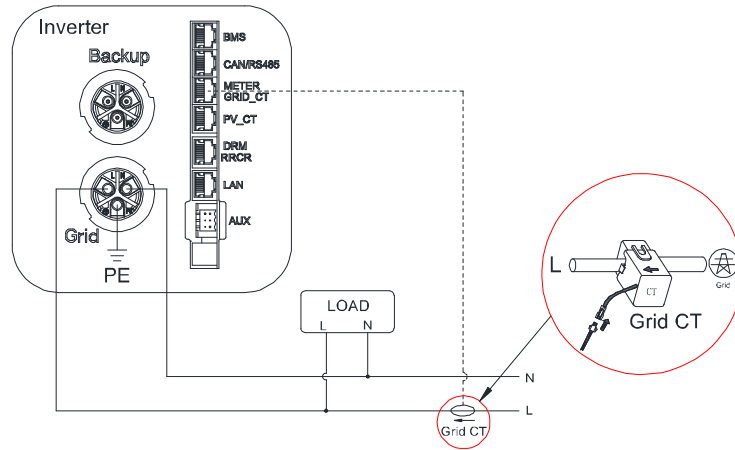

**DC-coupled Storage System**

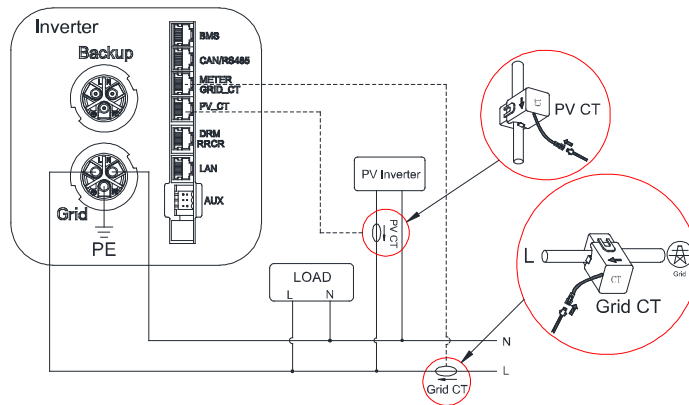

**AC-coupled Storage System and Hybrid-coupled Storage System**

**6.4.2. Meter Connection**

Loosen the swivel nuts of the cable glands on the COM connection cover, and unscrew the four screws on the corners, then you will see the meter communication ports.

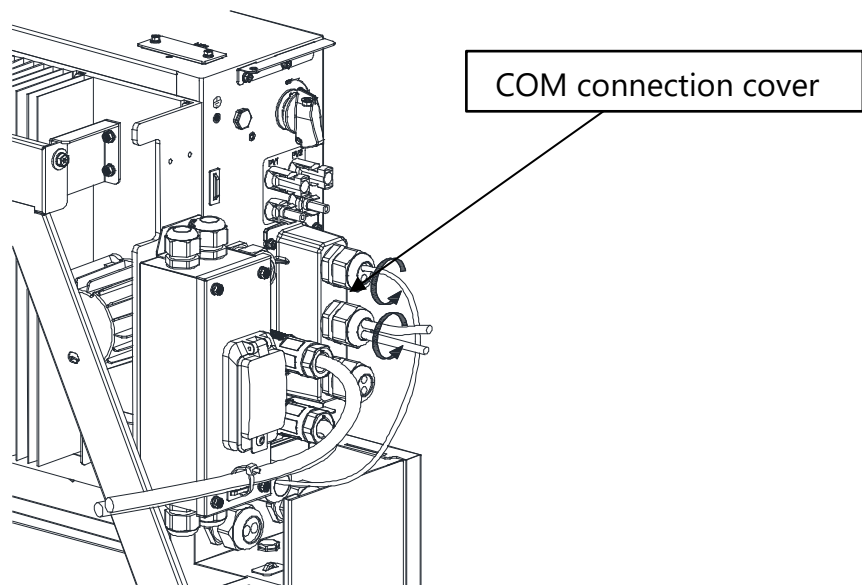

1. DSTU666-3\*230V 5(80)A: Three-phase meter (without CT) connection

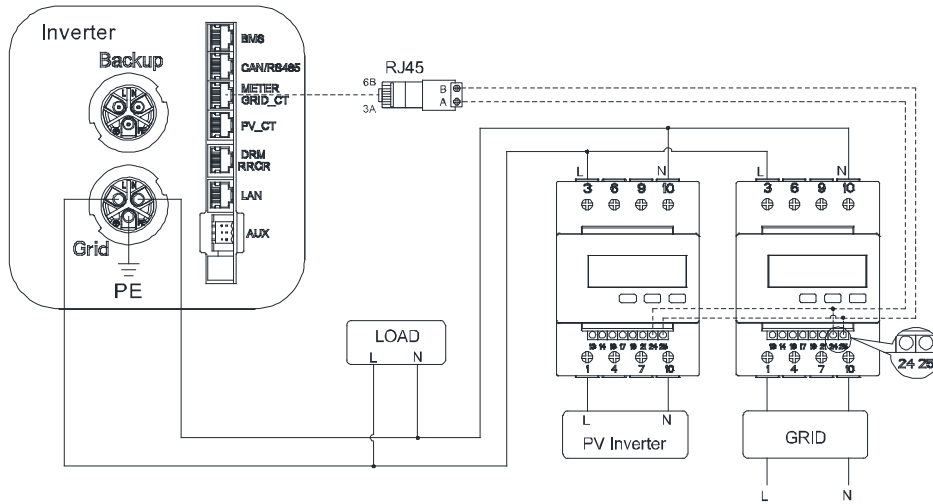

Wiring at single-phase feed-in

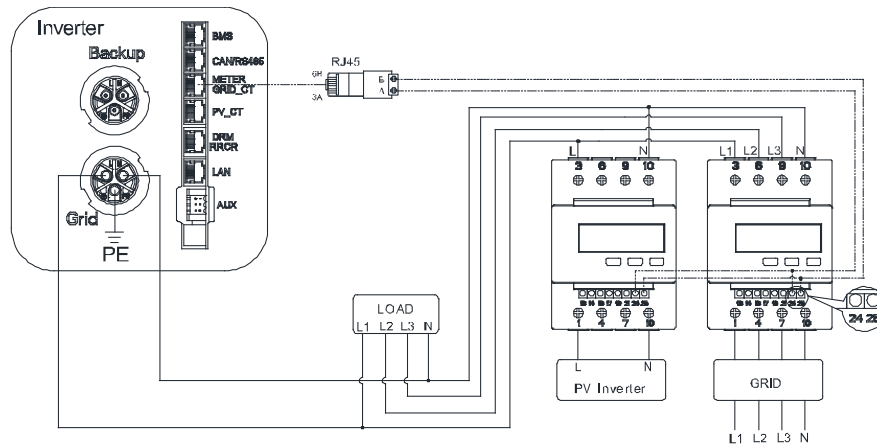

Wiring at three-phase feed-in

2. DSTU666-3\*230V 100A/40mA, DTSU666-3\*230V 250A/50mA: Three-phase meter (with CT) connection

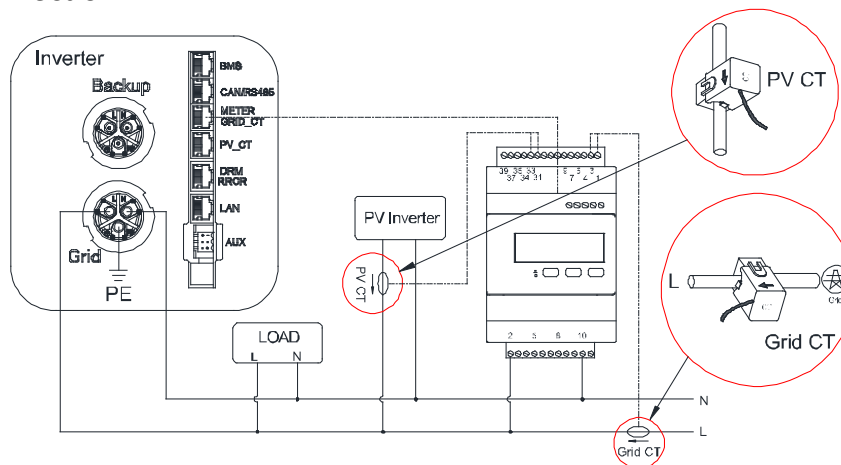

Wiring at single-phase feed-in

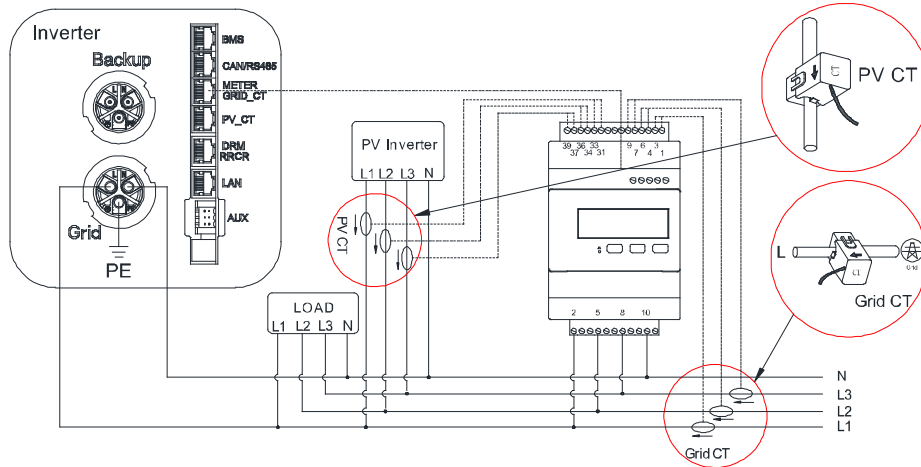

**Wiring at three-phase feed-in**

Grid CT	PV CT	GRID
1-----IA (White)	31-----IA(White)	2-----L1
3-----IA (Blue)	33-----IA (Blue)	5-----L2
4-----IB (White)	34-----IB (White)	8-----L3
6-----IB (Blue)	36-----IB (Blue)	10----- N
7-----IC (White)	37-----IC (White)	
9-----IC (Blue)	39-----IC (Blue)	

CT Group	Terminal	Colour
Grid -> Load	1	White
	3	Blue
	4	White
	6	Blue
	7	White
	9	Blue
PV -> Load	31	White
	33	Blue
	34	White
	36	Blue
	37	White
	39	Blue

**6.4.3. Configuring the Meter**

Model	Grid Meter Address	PV Meter Address
DTSU666-3*230V 5(80)A (without CT)	1	2
DTSU666-3*230V 100A/40mA (with CT)	1	N/A
DTSU666-3*230V 250A/50mA (with CT)	1	N/A

1. DTSU666-3\*230V 5(80)A: Three-phase meter (without CT)

When the meter is used as Grid meter, please follow the steps below to complete the address setting.

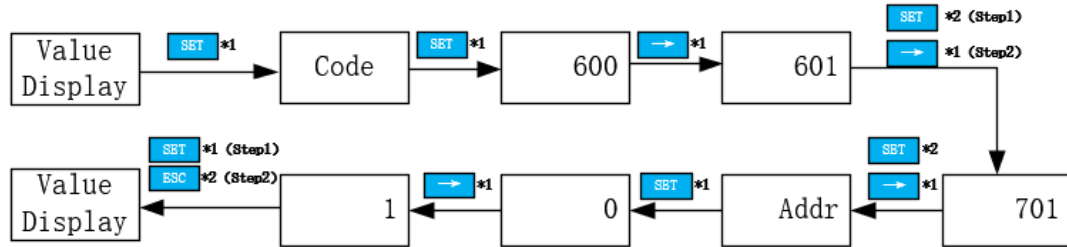

When the meter is used as PV meter, please follow the steps below to complete the address setting.

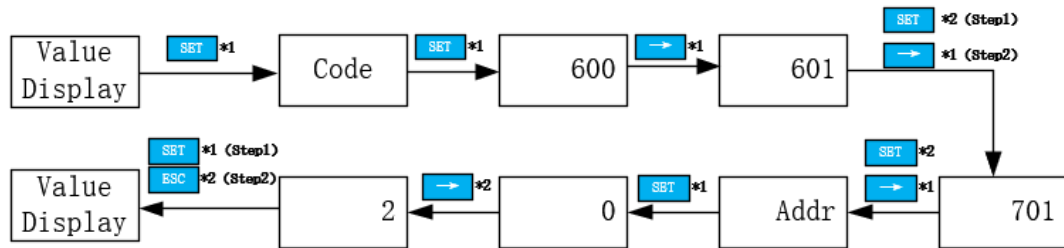

2. DTSU666-3\*230V 100A/40mA, DTSU666-3\*230V 250A/50mA: Three-phase meter (with CT)

Please follow the steps below to complete the address setting.

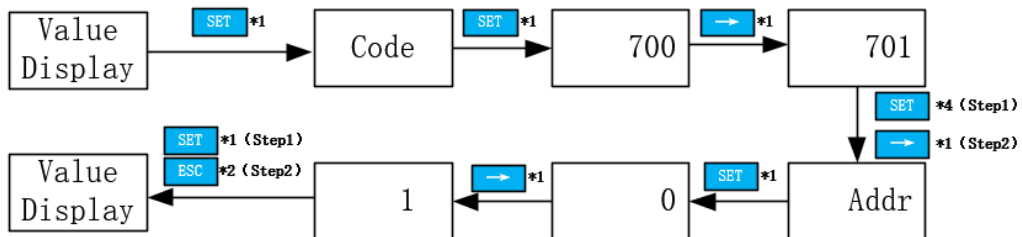

**Meter Setting on AlphaCloud**

**Step 1:**

When the system work mode is selected as DC, click the button under the "Grid Meter" to turn the "Meter" icon green.

When the system work mode is selected as AC or Hybrid, click the buttons under the "Grid Meter" and "PV side meter" to turn the "Meter" green.

**Step 2:**

Click "Save" and wait a few minutes to refresh the page. When the "Meter Model" displays DTSU666 model, the setting is successful.

**NOTE**

It is forbidden to tick CT to modify the CT ratio.

**Meter Setting on AlphaAPP**

**Step 1:**

When the system work mode is selected as DC, only tick "Meter" icon on the right of the "Grid Meter".

When the system work mode is selected as AC or Hybrid, both tick "Meter" icon on the right of the "Grid Meter" and "PV side meter".

**Step 2:**

Click "Submit" and enter the "System information" page to check the meter model. When the "Meter Model" displays DTSU666 model, the setting is successful.

**NOTE**

It is forbidden to tick CT to modify the CT ratio.

## 6.5. Communication Connection

### 6.5.1. AUX/LAN/PV-CT/DRM、RRCR/GRID-CT、Meter/RS485/BMS Connection

The pin definition of the communication ports:

AUX	1	2	3	4	5	6		
	DO1_NO	DO1_COM	DO1_NC	DI_negative	DI_positive	GND		
DRM RRCR	1	2	3	4	5	6	7	8
	DRED 1/5	DRED 2/6	DRED 3/7	DRED 4/8	REF GEN/0	COM LOAD/0	/	/
PV_CT	1	2	3	4	5	6	7	8
	/	/	RS485_A7	/	/	RS485_B7		/
GRID_CT METER	1	2	3	4	5	6	7	8
	/	/	RS485_A7	/	/	RS485_B7	/	/
RS485	1	2	3	4	5	6	7	8
	/	/	/	RS485_B5	RS485_A5	/	/	/
BMS	1	2	3	4	5	6	7	8
	/	RS485_A4	/	CAN1_H	CAN1_L	/	RS485_B4	/

For other communication (AUX, LAN, RRCR, DRM, Meter, CAN/RS485) connection, please follow the below steps.

Loosen the cable glands on the COM connection cover, and then unscrew the four screws on the COM connection cover.

Do communication connections as follow:

1. Lead the communication cables through the cable glands of the COM connection cover, don't tighten the swivel nuts of the cable glands.

Insert the RJ45 plugs to the relative RJ45 sockets.

For meter wiring, please refer to Chapter 6.4.2 Meter Connection.

If DRM support is specified, the system may only be used in conjunction with a Demand Response Enabling Device (DRED). This ensures that the system implements the commands from the grid operator for active power limitation at all times. The system and the Demand Response Enabling Device (DRED) must be connected in the same network.

Only DRM0 is available for SMILE-S5/B5.

Take out six pin terminal block for AUX connection. To do wiring connection, insert a screwdriver (blade width: 1.2 mm) into the relative connection position side.

For AUX position definition, please see the AUX wiring documentation.

2. Place the COM connection cover against the inverter housing and tighten the four screws, at last secure the swivel nut of the cable glands.

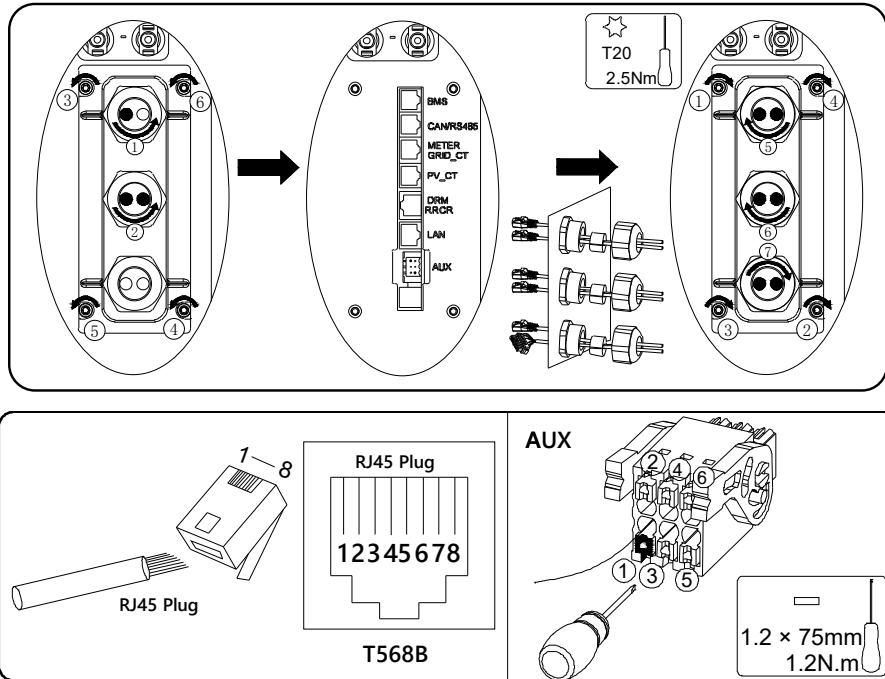

### 6.6. PV Connection

**This chapter is only suitable for SMILE-S5.**

Please ensure the follows before connecting PV strings to the inverter:

- Make sure the open voltage of the PV strings will not exceed the max. DC input voltage (600Vdc). Violating this condition will void the warranty.
- Make sure the polarity of the PV connectors is correct.
- Make sure the PV-switch, breakers of battery, AC-BACKUP and AC-Grid are all in their off-states.
- Make sure the PV resistance to ground is higher than 200KOhms.

The inverter uses the MC4 PV connectors. Please follow the picture below to assemble the MC4 connectors. PV conductor cross section requirement: 4~6 mm<sup>2</sup>

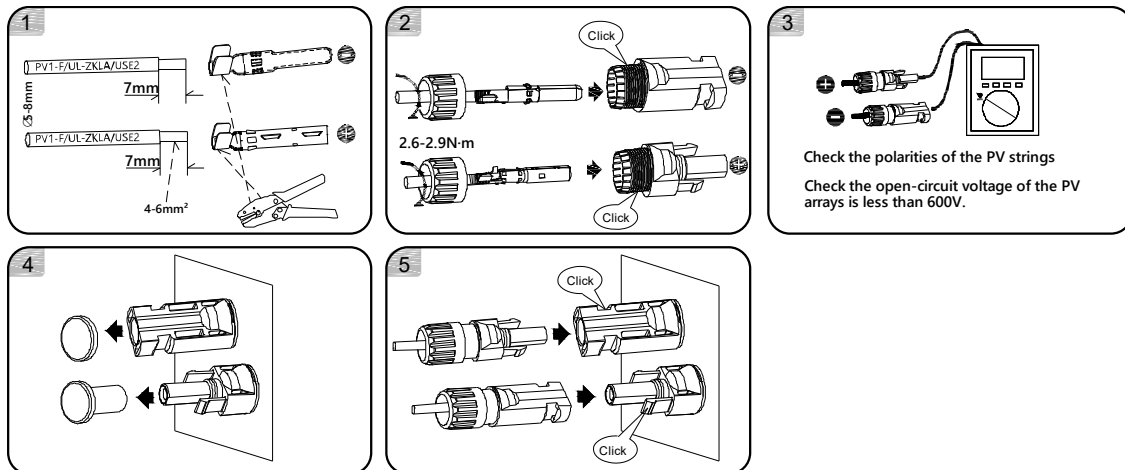

\*Only for SMILE-S5

### 6.7. Electrical Connection of Expandable Battery Packs

Please follow the below steps for battery pack expansion connection.

1. Remove the cable cover by unscrewing the M4 screw at the top manually.

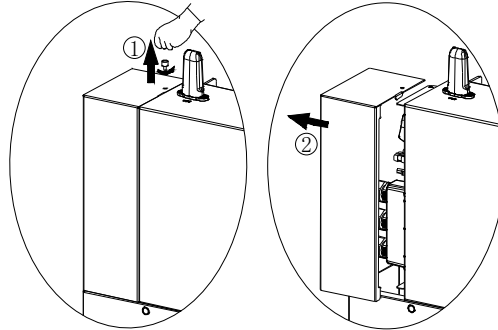

**Remove the rubber plugs from the battery cover, and then remove the cover after unscrewing all screws with T20 screwdriver.**

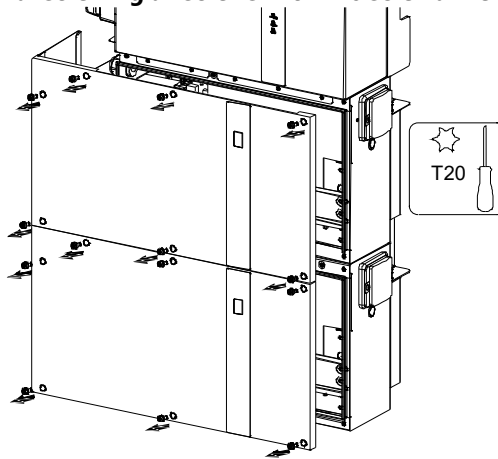

2. Do grounding connection between expandable battery packs.

Please prepare the grounding conductor, crimp the two ends with M5 OT terminals, and tighten them with T20 screwdriver (torque: 2.5 Nm).

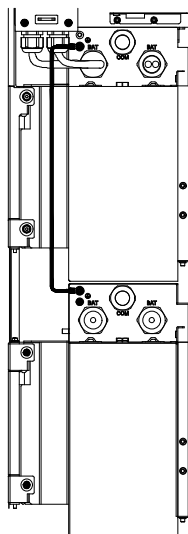

3. Unplug the terminal resistance from the first battery and insert it into the BMS communication port of the last battery (the battery furthest from the inverter).



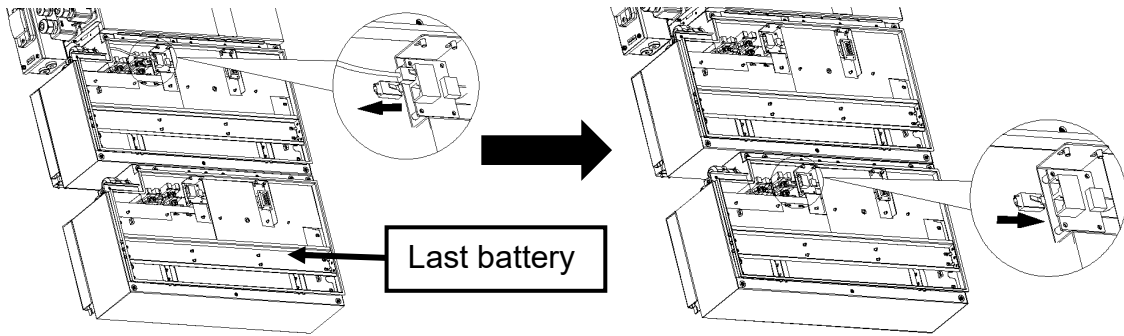

Last battery

4. Connect the positive power cable from battery 2 to battery 1 (tool: T20 screwdriver, torque: 3 Nm).

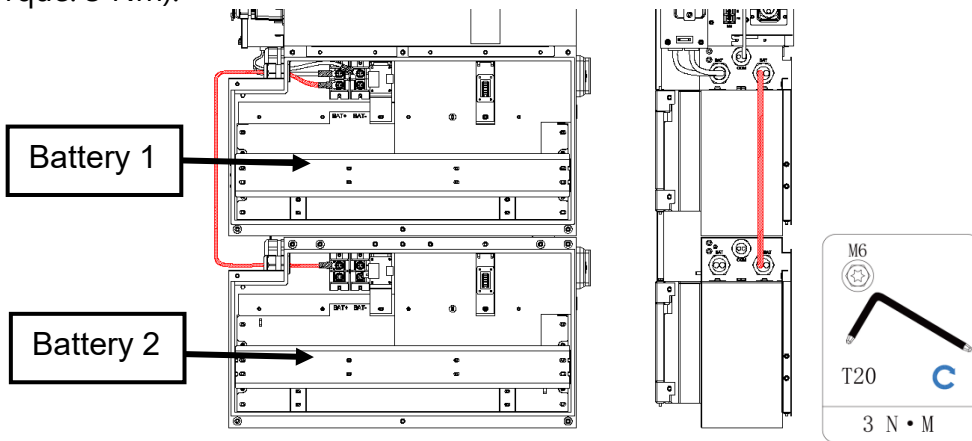

Battery 1

Battery 2

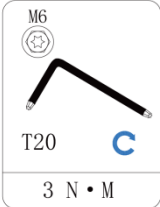

5. Connect the negative power cable from battery 2 to battery 1 (tool: T20 screwdriver, torque: 3 Nm).

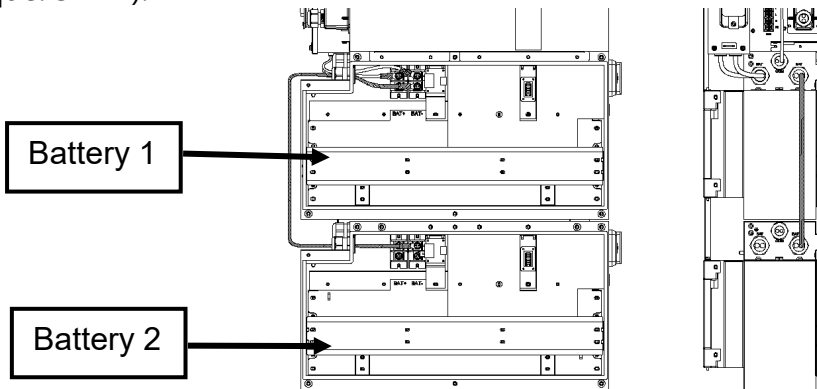

Battery 1

Battery 2

6. Connect the BMS communication cables from battery 2 to battery 1.

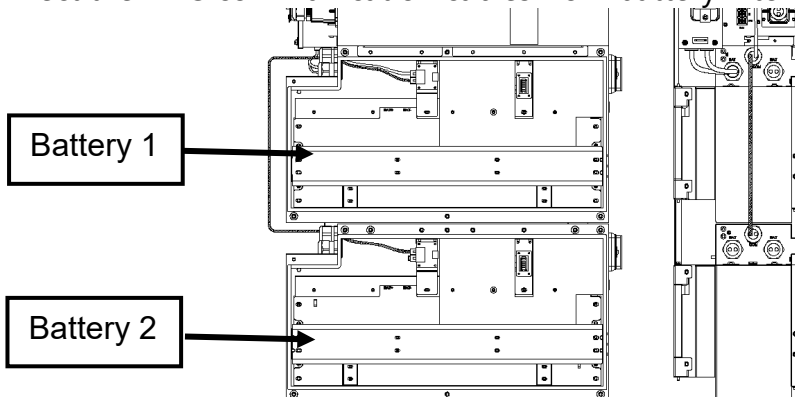

Battery 1

Battery 2

## 6.8. Mounting the Battery Cover and Cable Cover

After finishing electrical connection of expandable battery packs, do the following operations.

### Mounting the Battery Cover

1. Assemble front cover and side cover of the expandable battery with 3 M4 flange nuts (tools: SW7 sleeve, torque: 1.6 Nm).

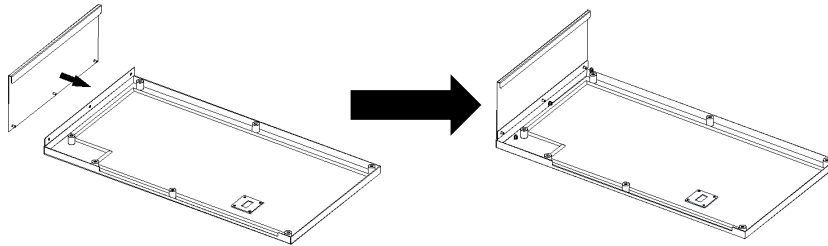

2. Attach the cover to the battery pack.

Fasten the cover on the battery with seven M5\*12 screws in sequence 1-7 (tool: T20 screwdriver).

**NOTE**

Seven screws should be pre-tightened and then tighten all screws (torque: 2.5 Nm  $\pm$  0.3 Nm).

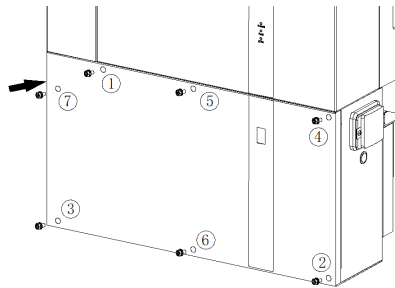

3. Insert the silicone plugs into the screw holes of the battery cover.

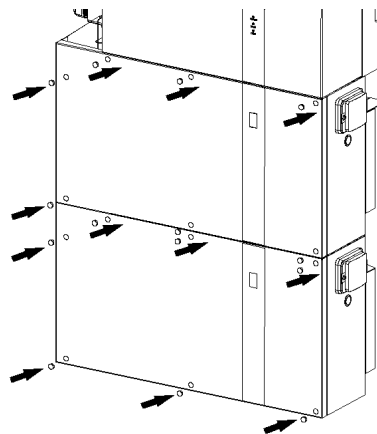

### Mounting the Cable Cover

- a. Unscrew the two screws, take out the holder for cable cover from package and hang on the screws, then tighten the two screws.
- b. Insert the cable cover in the order shown by the arrow as following figure until the cable cover is mounted in place.
- c. Fix the cable cover by tightening the M4 screws manually on the top.

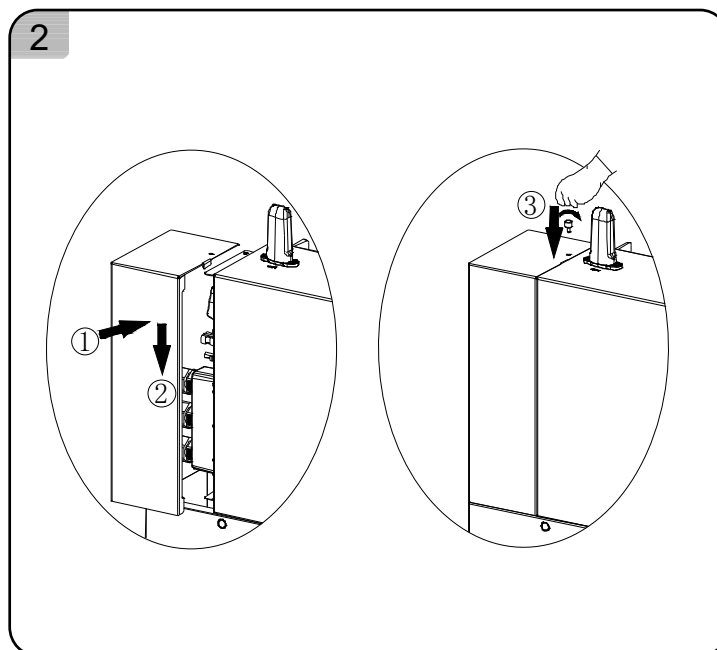
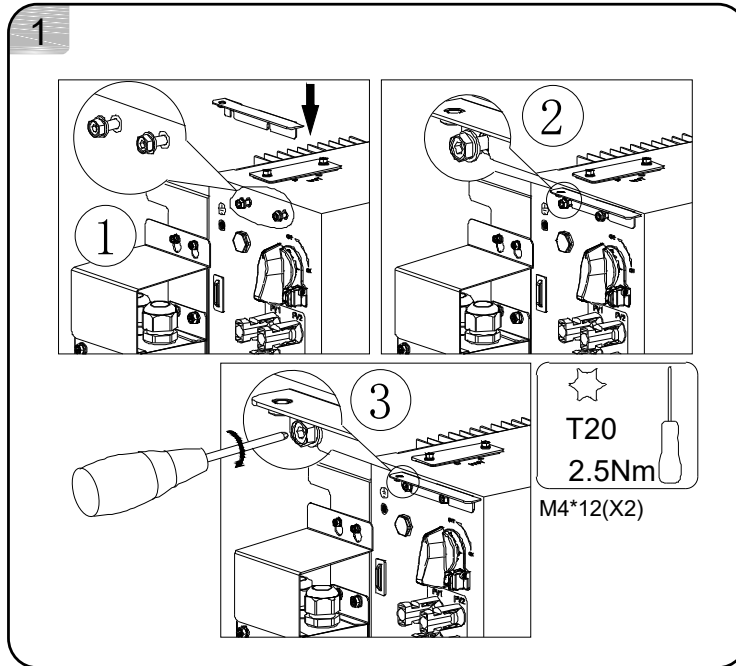

## 7. Installer Account Register and Install New System

### 7.1. Registration on APP

#### 7.1.1. Download and Install APP

1. Android device users can download the App through major Android application markets such as Google Play.
2. IOS device users can search for "AlphaESS" in App Store and download the App.



AlphaESS-APP

#### 7.1.2. Register as Installer Account

If you don't have an installer account, please register firstly.

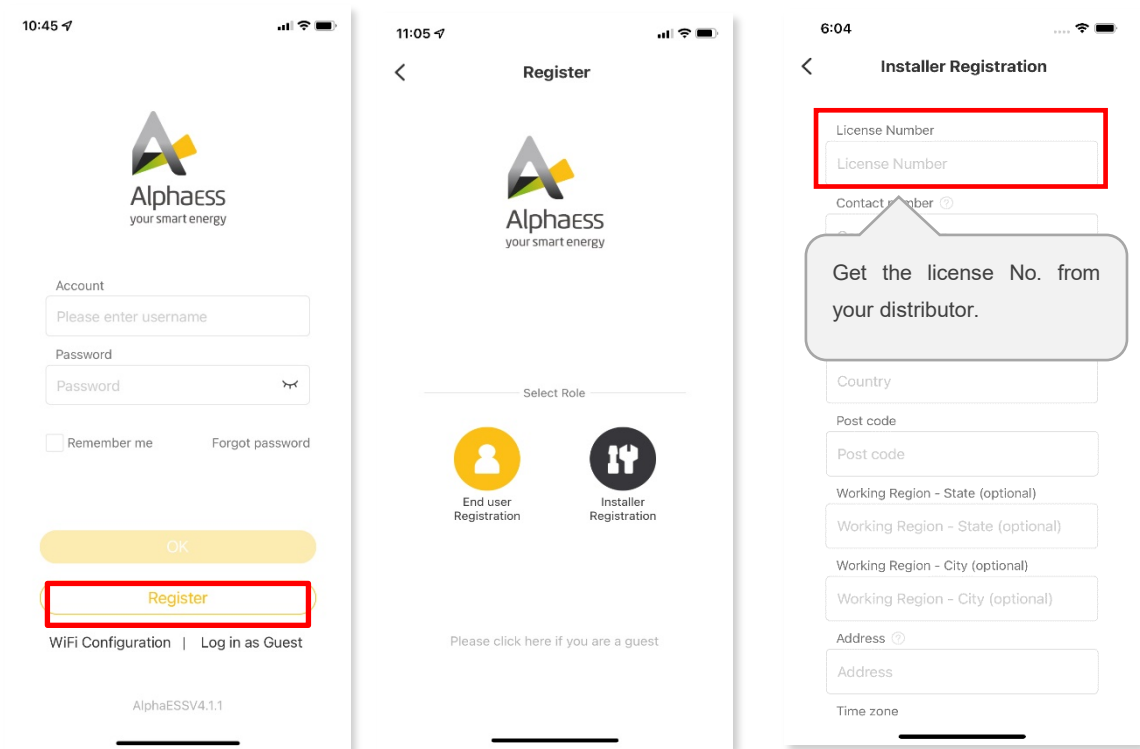

If you already have an installer account, please log in directly.

### 7.1.3. Overview of Functions for Installer Account

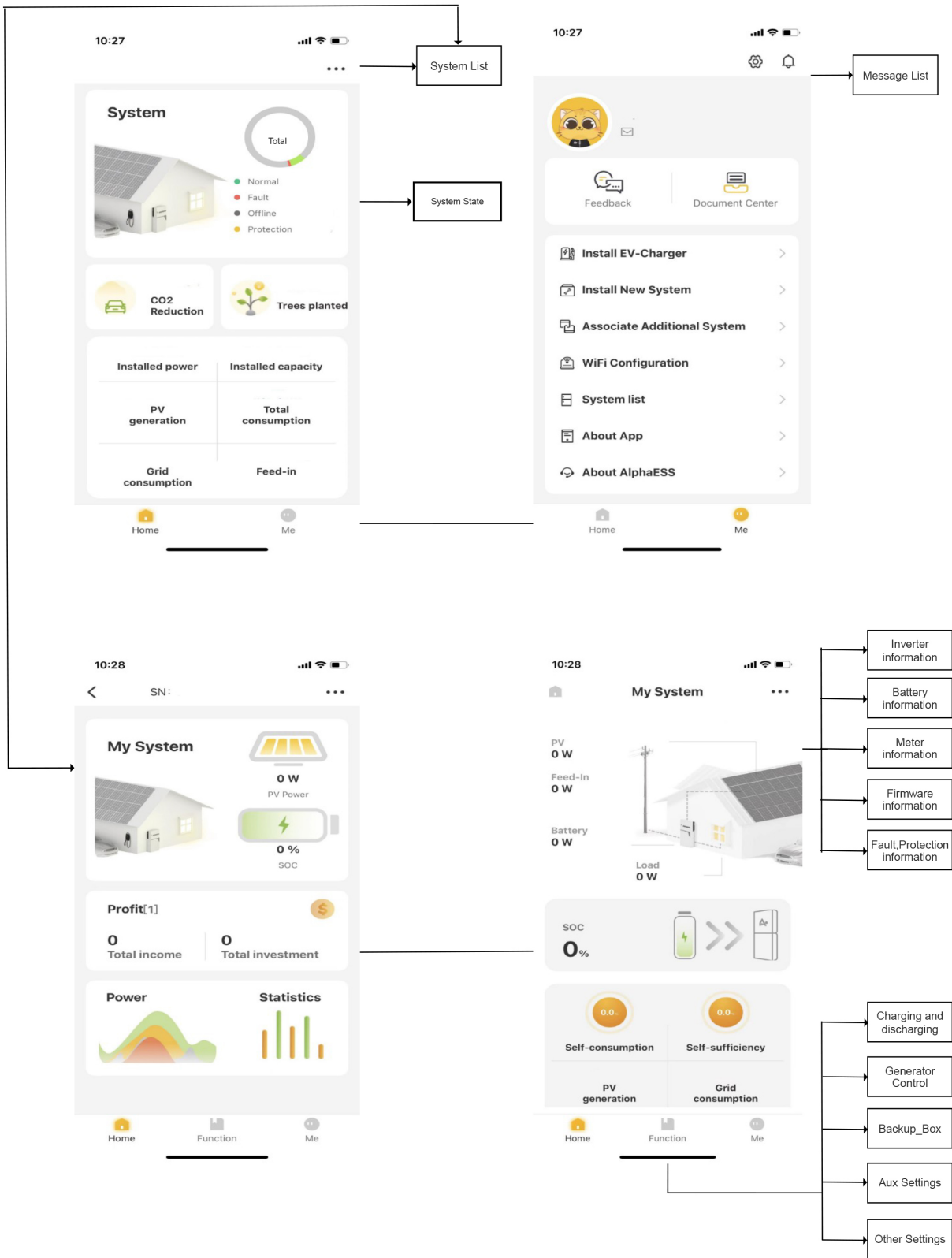

### 7.1.4. Install New System

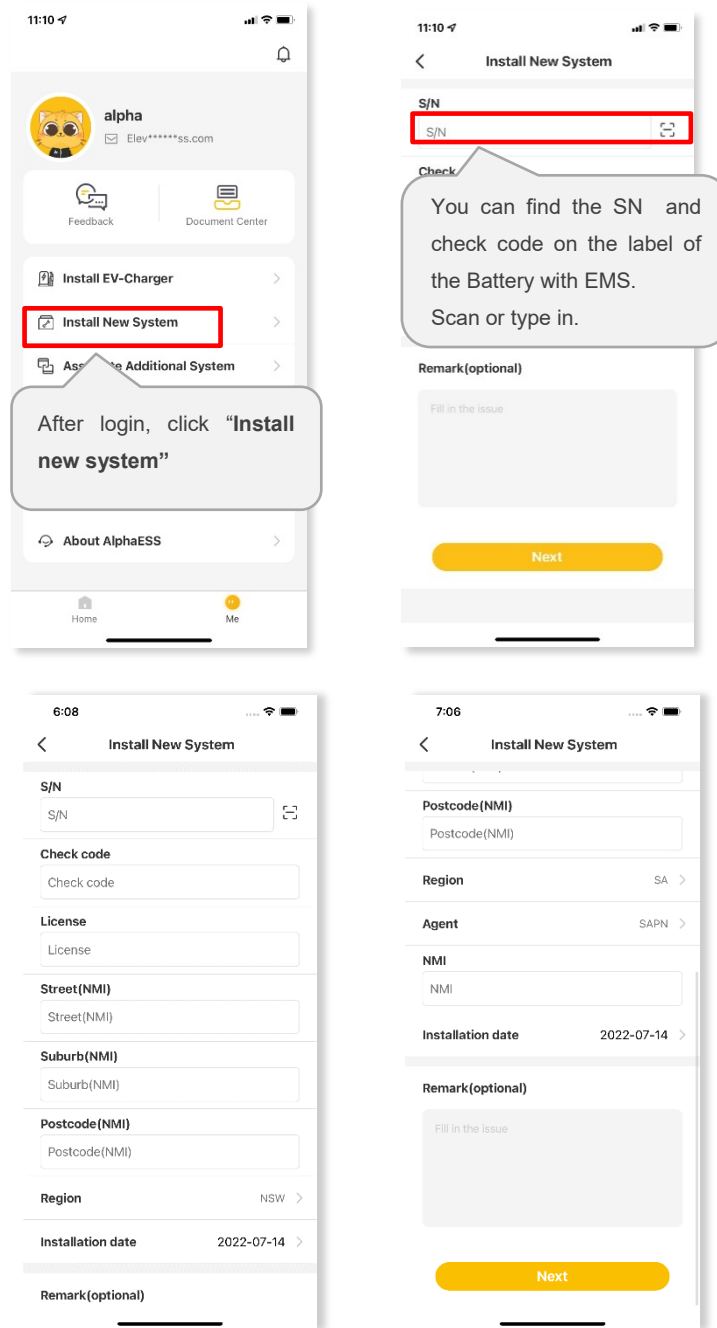

#### Australian Installer

Please enter your installer account and click install New system to register the system to your account and set the system.

Enter S/N, check code, license, create time, customer full name, contact number, address, and click the save button. If you are an Australian installer, you will need to

fill in the Street (NMI), Suburb (NMI) and Postcode (NMI) fields and add a new Region field, which has six fixed options (NSW, QLD, VIC, SA, TAS, WA). If SA is selected for Region, two more fields are added which are Agent and NMI.

Fields that are not marked "optional" need to be filled in.

Click "Next" to go to the installation steps interface.

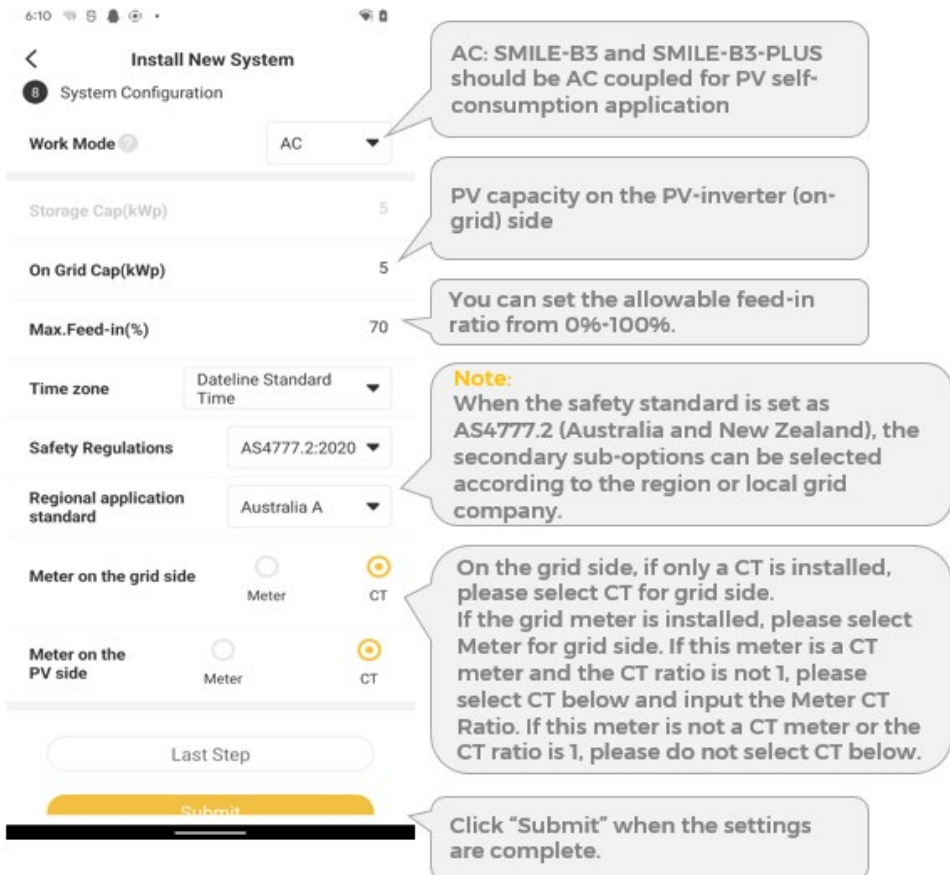
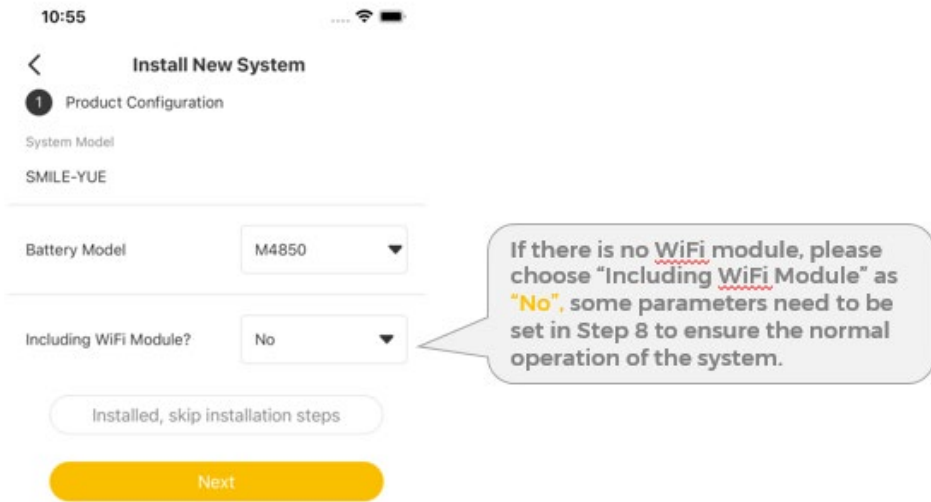

**! NOTICE**

**The safety standard must be set correctly**

If you select a safety standard which is not valid for your country and purpose, it can cause a disturbance in the energy storage system and lead to problems with the grid operator. When selecting the safety standard, you must always observe the locally applicable regulations and directives as well as the properties of the PV system (e.g. PV system size, grid-connection point).

- If you are not sure which safety standard is valid for your country or purpose, contact your grid operator for information on which safety standard is to be configured.

If there is a WiFi module, please choose "Including WiFi Module" as "Yes", the APP will jump to the WiFi configuration page, and please refer to section 9.3.

**7.2. Register on AlphaCloud**

**7.2.1. Register as Installer Account**

You can create a new account on our webserver for the normal monitoring. In addition, a part of our warranty is based on this connection to our webserver. The data produced prior to registration can be synchronized to the webserver.

**Step1:** Please use the following steps: Open the portal: [www.alphaess.com](http://www.alphaess.com).

**Step2:** Please fill in "Username", "Password" and click "Login" if you have already registered.

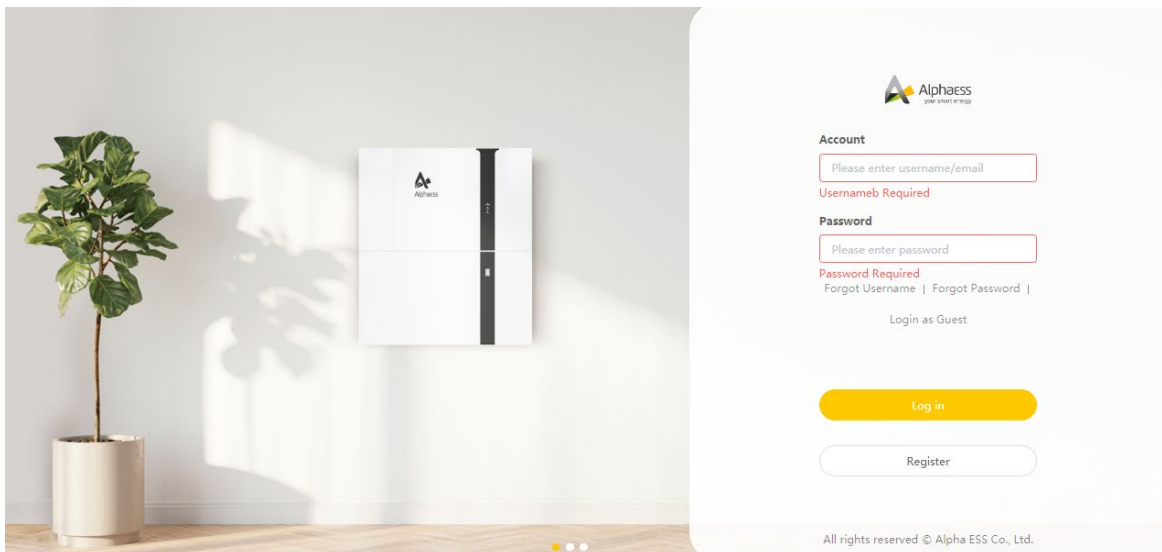

If not, please register by filling in the following web form;



### User registration

<b>* User Type</b> <input type="text" value="End user"/>	<b>* SN</b> <input type="text" value="Please enter system SN"/>	<b>* SN check code</b> <input type="text" value="Please enter the SN che"/>
<b>* Username</b> <input type="text" value="someone@example.com"/>	<b>* Zip Code</b> <input type="text" value="Please enter your zip code"/>	
<b>* Password</b> <input type="text" value="Please enter the password"/>	<b>* Confirm Password</b> <input type="text" value="Please confirm the password"/>	
<b>Language</b> <input type="text" value="English"/>	<b>* Contact Person</b> <input type="text" value="Please enter a contact"/>	
<b>* Country / Region</b> <input type="text" value="Please select your coun"/>	<b>Province/State</b> <input type="text" value="Please select your provin"/>	<b>City/Town</b> <input type="text" value="Please select your city"/>
<b>Address</b> <input type="text" value="Please enter your address"/>	<b>Contact Number</b> ⓘ <input type="text" value="Please enter your phone number"/>	
<b>* Time Zone</b> <input type="text" value="Please select a time zone"/>	<b>* Installation Time</b> <input type="text" value="Please select an installation date"/>	

Whether to allow automatic update (the automatic upgrade function is to actively update the latest push program to improve the use of the device when the system is online.)

Agree to the above terms [《Terms and Conditions》](#) and [《Privacy Policy》](#)

Back
Submit

In this form, all fields with a red star are compulsory, and you can select the finally users or installation procedures.

**\*Serial number:** EMS serial number (please see the label located at the inverter right side)

**\*Username:** 5-15 letters / numbers

**\*Password:** 5-15 letters / numbers / characters

More details are available in the Online Monitoring Web Sever Installers User Manual, which can be downloaded from AlphaESS homepage.

### 7.2.2. Install New System

Installers who have not yet registered need to click "Register" to visit the registration page. Please refer to "AlphaCloud Online Monitoring Webserver Installers User Manual", which you can get from AlphaESS sales and get license number from relevant sales from AlphaESS.

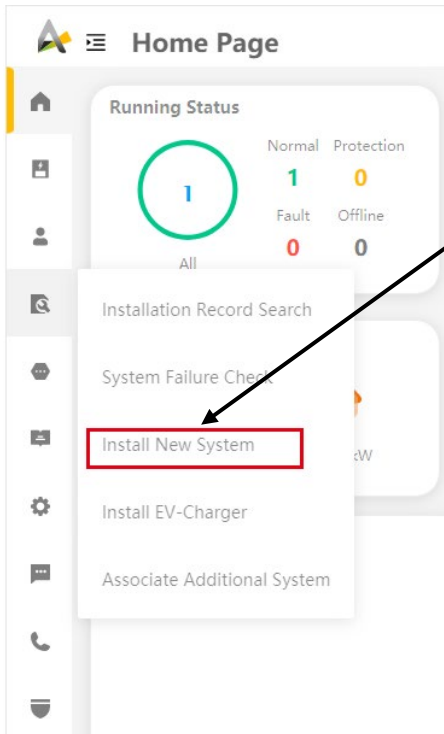

The screenshot shows the 'Home Page' dashboard. A sidebar menu on the left contains several options, with 'Install New System' highlighted by a red box. A callout box with a black border and white background contains the text: 'Log in to your installer account and choose Storage System Maintenance > "Install new system" to register new system at Alpha ESS.' An arrow points from this callout box to the 'Install New System' menu item.

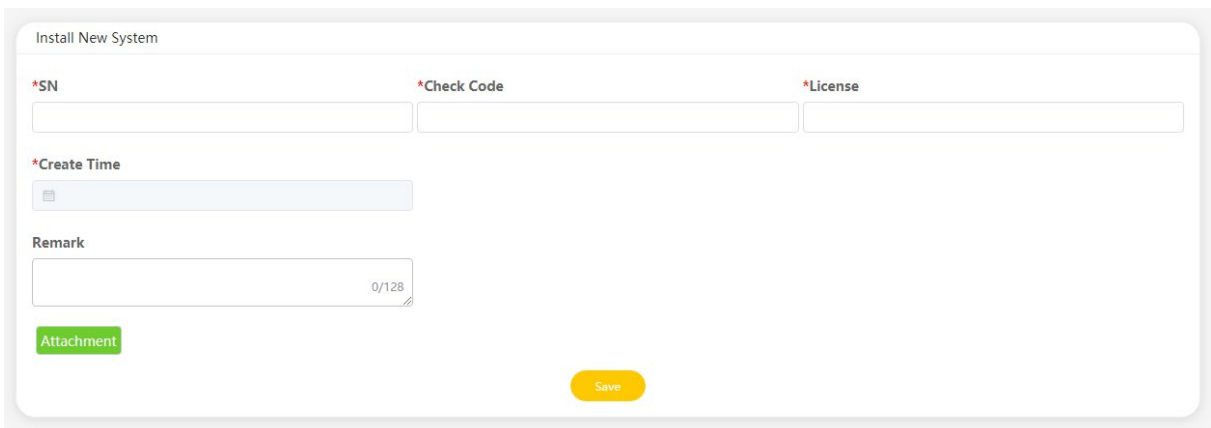

The screenshot shows the 'Install New System' form. It contains the following fields:

- \*SN: A text input field.
- \*Check Code: A text input field.
- \*License: A text input field.
- \*Create Time: A date and time picker.
- Remark: A text area with a character count of 0/128.
- Attachment: A green button labeled 'Attachment'.
- Save: A yellow button labeled 'Save'.

Enter the system S/N, check code, license, installation date and click the save button. The red \* in front of it is required. Click the Browse button to select the attachment you want to add.

## 8. Powering On and Off the product

### 8.1. Powering on the Product

#### Procedure

- 1) Switch on the battery breaker at right side of the battery.
- 2) Switch on the battery breaker located at the middle left of the energy storage inverter.
- 3) Press the power button of the battery, if there are more than one battery, the button for each battery should be pressed within 5 seconds of the previous one.
- 4) Switch on the AC breaker between the grid port of the inverter and the grid.
- 5) Switch on the AC breaker between the backup port of the inverter and the loads.
- 6) Switch on the PV switch on the left side of the inverter.
- 7) Switch on the PV switch between the PV string and the inverter if there is any.

### 8.2. Powering off the Product



#### WARNING

After the energy storage system is powered off, the remaining electricity and heat may still cause electric shocks and body burns. Therefore, put on protective gloves and operate the product 5 minutes after the power-off.

#### Procedure

- 1) Switch off the AC breaker between the energy storage inverter and the load.
- 2) Switch off the PV switch at the upper left of the energy storage inverter.
- 3) Switch off the PV switch between the PV string and the energy storage inverter if there is any.
- 4) Long press the power button of the battery for 6 seconds, and then switch off the battery breaker located at right side of the battery.
- 5) Switch off the battery breaker located at the middle left of the energy storage inverter.
- 6) Switch off the AC breaker between the energy storage inverter and the grid.

## 9. COMMISSIONING

### 9.1. Checking Before Power-On

No.	Check Item	Acceptance Criteria
1	Mounting environment	The mounting space is proper, and the mounting environment is clean and tidy, without foreign object.
2	Expandable battery pack and Smile-S5/B5 mounting	The expandable battery pack and Smile-S5/B5 are mounted correctly, securely, and reliably.
3	WiFi mounting	The WiFi module is mounted correctly, securely, and reliably
4	Cable layout	Cables are routed properly as required by the customer.
5	Cable tie	Cable ties are secured evenly and no burr exists.
6	Grounding	The grounding cable is connected correctly, securely, and reliably.
7	Switch and breakers status	The PV switch if there is any and battery breakers and all the breakers connecting to the product are OFF.
8	Cable connections	The AC cable, PV cable (if there is any), battery cable, and communication cables are connected correctly, securely, and reliably.
9	Unused power terminals	Unused power terminals are blocked by watertight caps.

### 9.2. Powering on the Product

- Check the voltage range and frequency range of the grid and the installation of CT(s) or meter(s).
- Switch on the battery breaker of the battery.
- Switch on the battery breaker located on the energy storage inverter.
- Switch on the external AC breaker between the grid and the energy storage inverter.
- Firstly, don't press the battery button, don't switch on the PV switch on the energy storage inverter (if there is any) and don't switch on the AC breaker on the PV inverter if there is any.

### 9.3. WiFi Module Configuration and Parameter Settings

#### 9.3.1. WiFi Configuration

This section is for users who have an energy storage system with a WiFi module. AlphaESS App supports network configuration, setting of the system basic parameter, monitor system operation status and check configuration information.

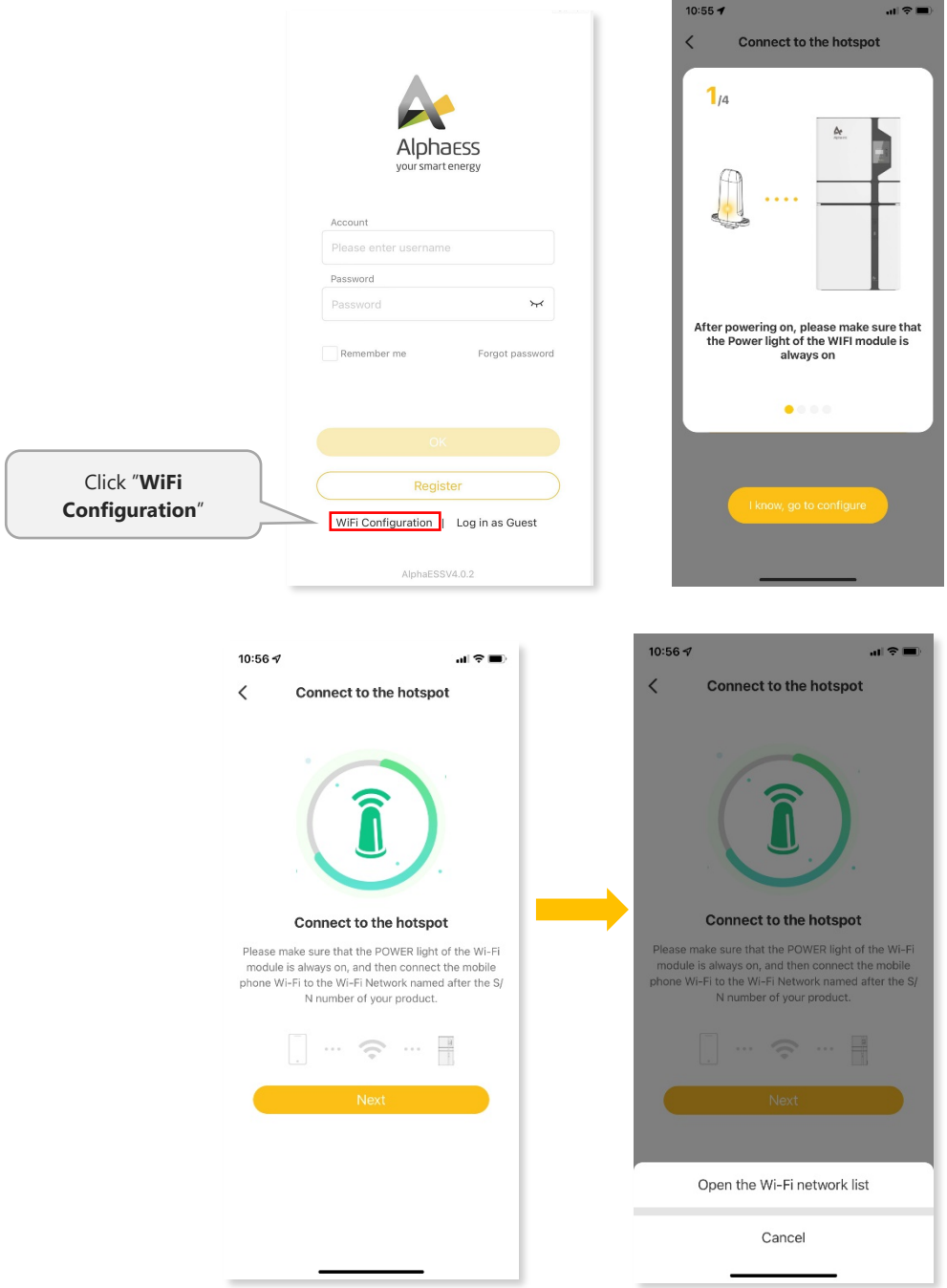

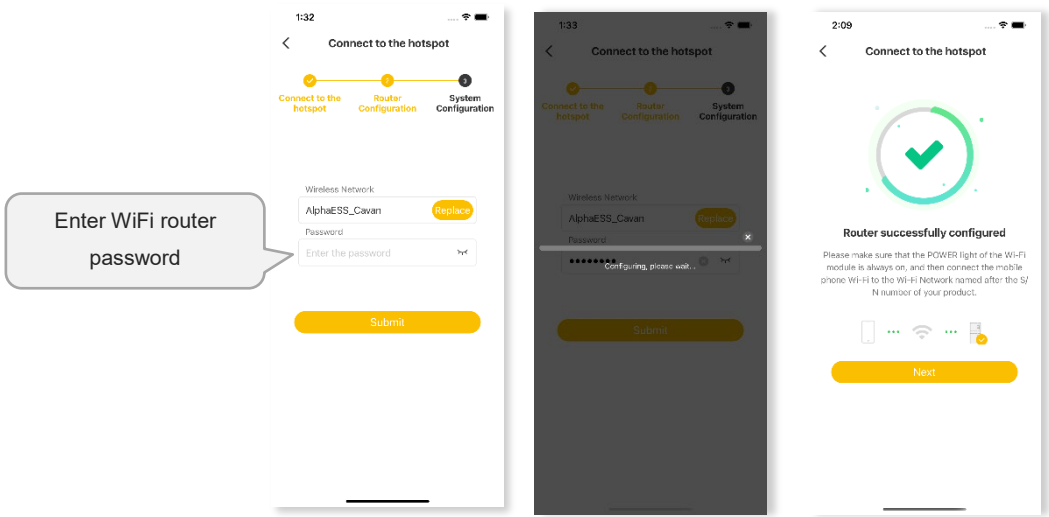
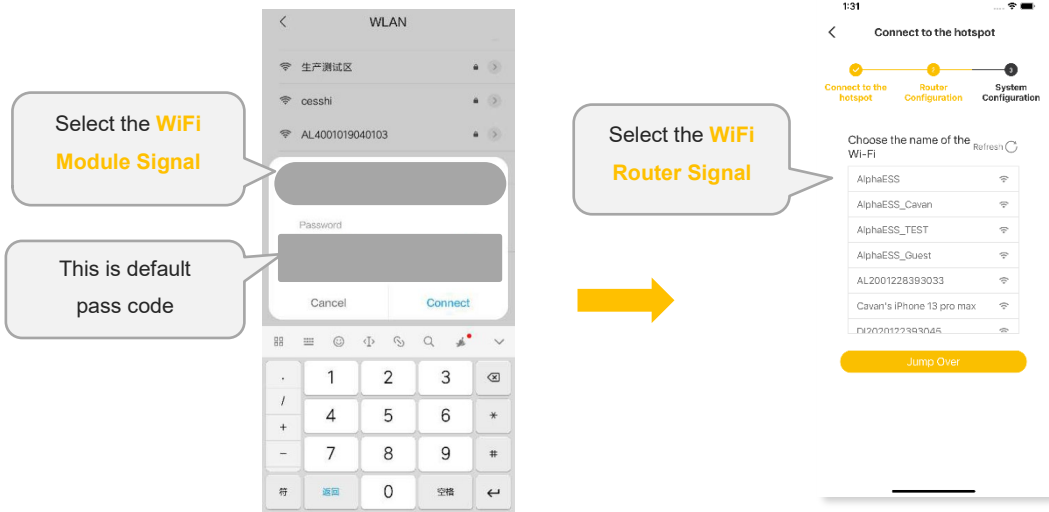

**NOTE**  
The system will not be able to connect to the internet without WiFi configuration.

### 9.3.1.1 Basic Parameters Settings

#### DC Mode

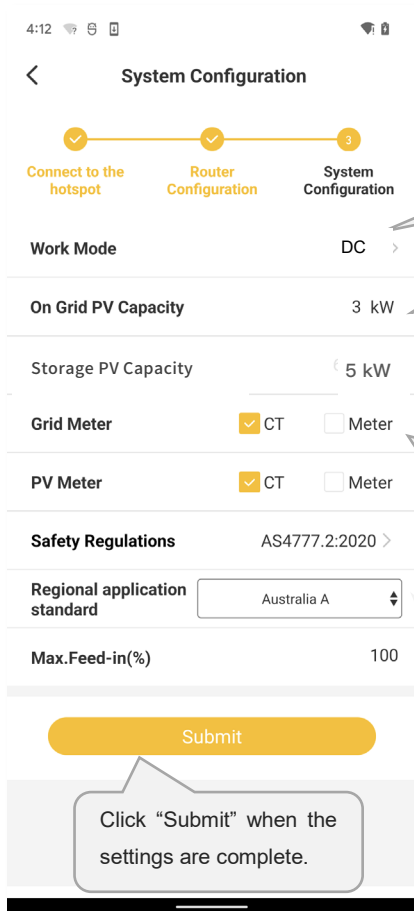
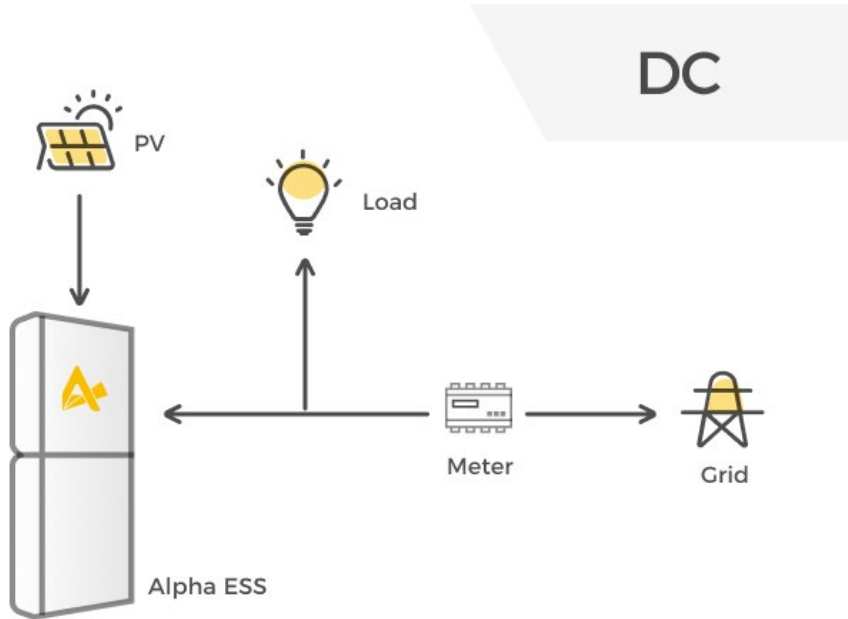

Three mode options: **DC/AC/Hybrid**

Storage PV capacity: PV capacity on the energy storage inverter side

On the grid side, if only a CT is installed, please select CT for grid side. If the grid meter is installed, please select Meter for grid side. If this meter is a CT meter and the CT ratio is not 1, please select CT below and input the Meter CT Ratio. If this meter is not a CT meter or the CT ratio is 1, please do not select "CT" below.

You can set the allowable feed-in ratio from 0%-100%.

Click "Submit" when the settings are complete.

**Note:** When the safety standard is set as AS4777.2 (Australia and New Zealand), the secondary sub-options can be selected according to the region or local grid company(Please refer to Appendix 2). Once the safety regulation is chosen during the WIFI setting, only the Alpha service engineer can change the safety regulation and the setpoints for the power quality response modes. Please contact Alpha ESS to change settings when necessary.

AC Mode

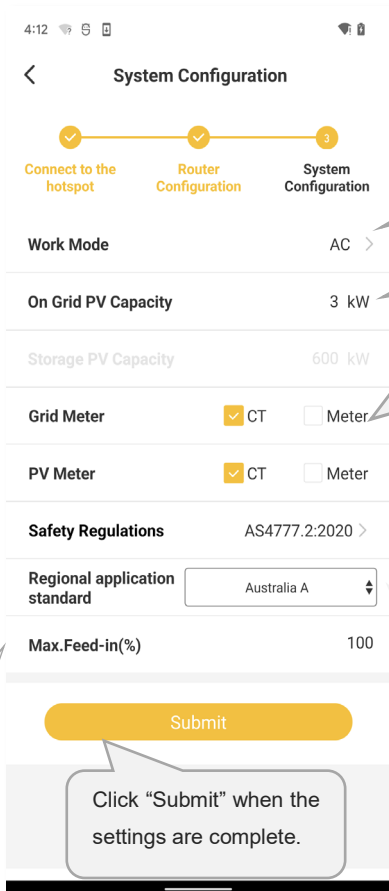
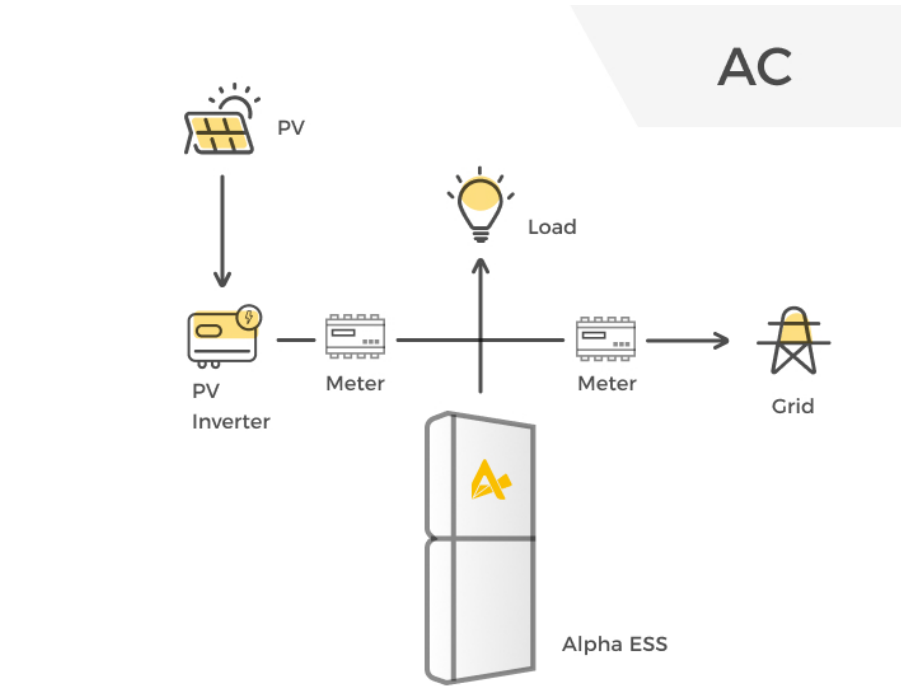

Three mode options: DC/AC/Hybrid

PV capacity on the PV-inverter (on-grid) side

On the grid side, if only a CT is installed, please select CT for grid side. If the grid meter is installed, please select Meter for grid side. If this meter is a CT meter and the CT ratio is not 1, please select CT below and input the Meter CT Ratio. If this meter is not a CT meter or the CT ratio is 1, please do not select "CT" below. Please refer to the above steps to set the PV-CT or meter on PV side.

You can set the allowable feed-in ratio from 0%-100%.

**Note:** When the safety standard is set as AS4777.2 (Australia and New Zealand), the secondary sub-options can be selected according to the region or local grid company(Please refer to Appendix 2). Once the safety regulation is chosen during the WIFI setting, only the Alpha service engineer can change the safety regulation and the setpoints for the power quality response modes. Please contact Alpha ESS to change settings when necessary.

SMILE-B5 work as AC coupled energy storage system.



### Hybrid Mode

# Hybrid

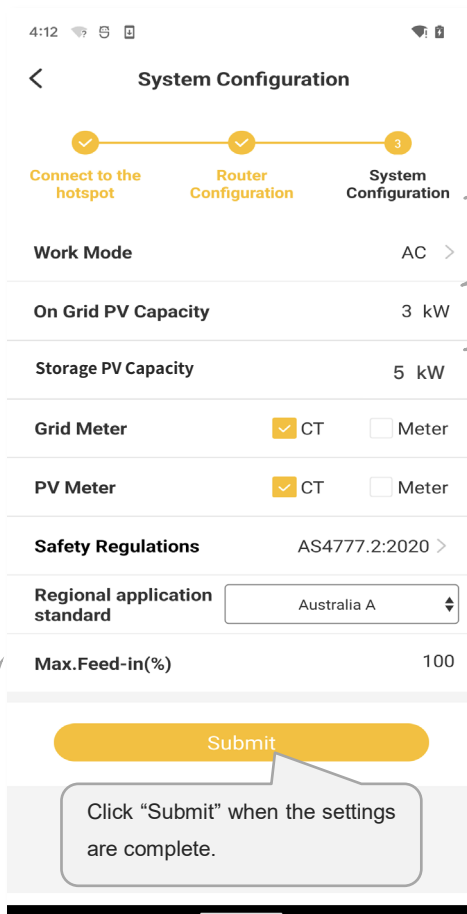
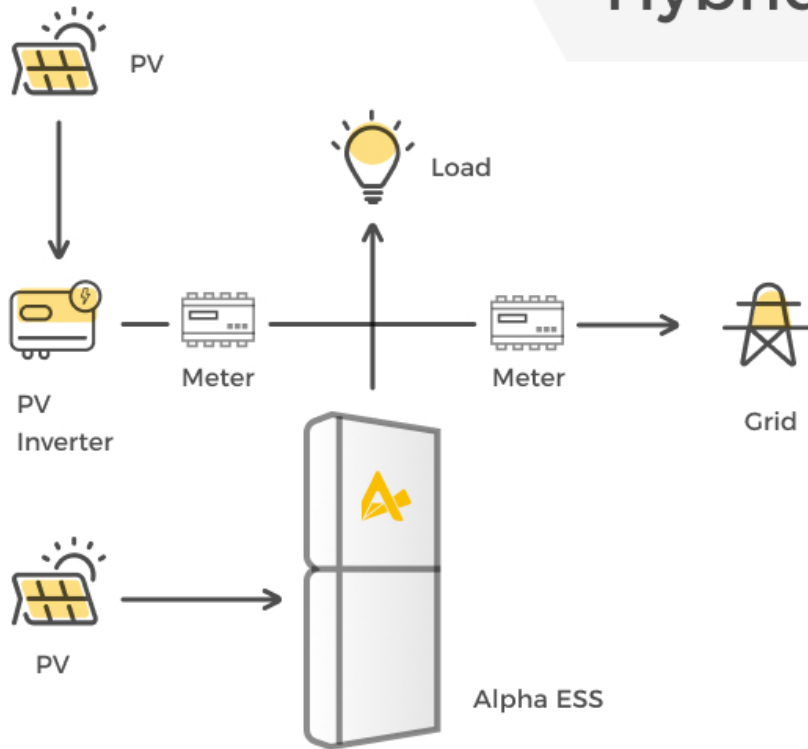

Three mode options: DC/AC/**Hybrid**

PV capacity on the PV-inverter (on-grid) side

Storage PV capacity: PV capacity on the energy storage inverter side

On the grid side, if only a CT is installed, please select CT for grid side. If the grid meter is installed, please select Meter for grid side. If this meter is a CT meter and the CT ratio is not 1, please select CT below and input the Meter CT Ratio. If this meter is not a CT meter or the CT ratio is 1, please do not select "CT" below. Please refer to the above steps to set the PV-CT or meter on PV side.

**Note:**

When the safety standard is set as AS4777.2 (Australia and New Zealand), the secondary sub-options can be selected according to the region or local grid company(Please refer to Appendix 2). Once the safety regulation is chosen during the WIFI setting, only the Alpha service engineer can change the safety regulation and the setpoints for the power quality response modes. Please contact Alpha ESS to change settings when necessary.

You can set the allowable feed-in ratio from 0%-100%.

Click "Submit" when the settings are complete.

**NOTICE**

**The safety standard must be set correctly**

If you select a safety standard which is not valid for your country and purpose, it will cause a disturbance in the energy storage system and lead to problems with the grid operator. When selecting the safety standard, you must always observe the locally applicable standards and directives as well as the properties of the PV system (e.g. PV system size, grid-connection point).

- If you are not sure which safety standard is valid for your country or purpose, please contact your grid operator for information on which safety standard is to be configured.

**9.3.2. Direct Commissioning on WiFi configuration**

You can commission the system during the WiFi configuration process directly.

**9.3.2.1 Check the Running State without PV and Battery**

- Keep the PV switch of the energy storage inverter and AC breaker of the PV-inverter off. Don't power on the batteries.
- Turn on some larger loads directly connected on the grid to check the grid status, the inverter LED ("Fault") will be red, don't worry, because the battery is not communicated. The grid power should be positive. Otherwise please check the direction of grid CT or grid meter installation.

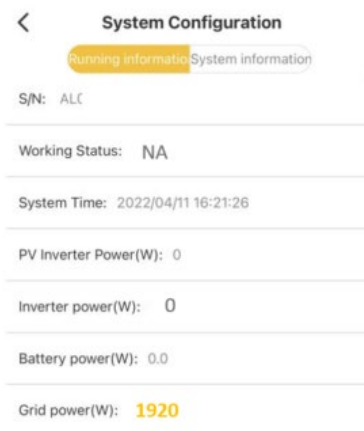

**9.3.2.2 Check the Running State of PV and Battery**

- Switch off the AC breaker between the grid port on the energy storage inverter and the grid, and switch off the AC breaker between the backup port on the energy storage inverter and the loads.
- Press the battery button. If there are more than one battery, press the button of each battery and the interval time of powering on any two batteries should be less than 5s.
- Switch on the AC breaker between the grid port of the energy storage inverter and the grid.
- Switch on the PV switch on the energy storage inverter if there is any and AC breaker on the PV-inverter if there is any.
- Switch off all the loads to see the battery charging status and the inverter LED ("Normal") will be solid on green. Battery power value should be negative. If the system is in AC or hybrid mode, the PV inverter power value should be positive. If it is not normal, please check the direction of PV CT or PV meter installed.

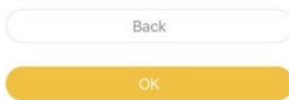
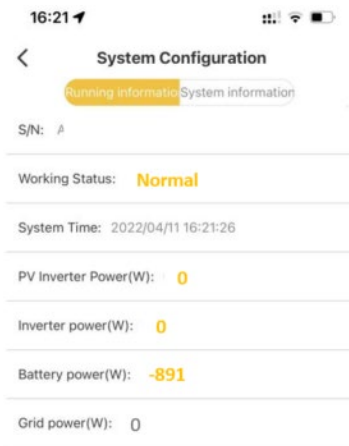

**DC Mode**

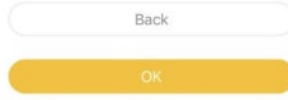

**AC Mode**

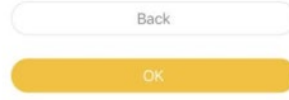

**Hybrid Mode**

### 9.3.2.3 Check the UPS State

- Please connect an essential electrical appliance to the socket of backup load. Or switch on an essential electrical appliance already connected on the backup load port of the energy storage inverter.
- Switch on the AC breaker on the backup port of the energy storage inverter.
- Switch off the external AC breaker between the grid and the energy storage inverter.
- The product will enter the UPS mode at once.
- If the electrical appliance on backup side can work normally, it means that the wiring of the backup has been connected correctly.

#### UPS

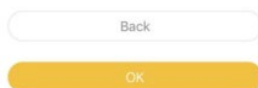
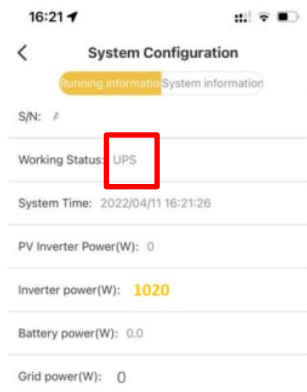

**NOTICE**

During commissioning, if the LED indicators on the display panel of the inverter or the battery pack show red, please refer to chapter troubleshooting.

**9.3.3. Check the basic parameters**

To make sure the system is installed and operating correctly, please check the basic parameter after finishing the setting.

All the stauts can be found via the main page. On the main page, tap "your device" to view the information for the system. The firmware version can be checked in the "Firmware information", and the safety regulations, the power quality modes and setpoints can be viewed through the "inverter information".

**Step1**

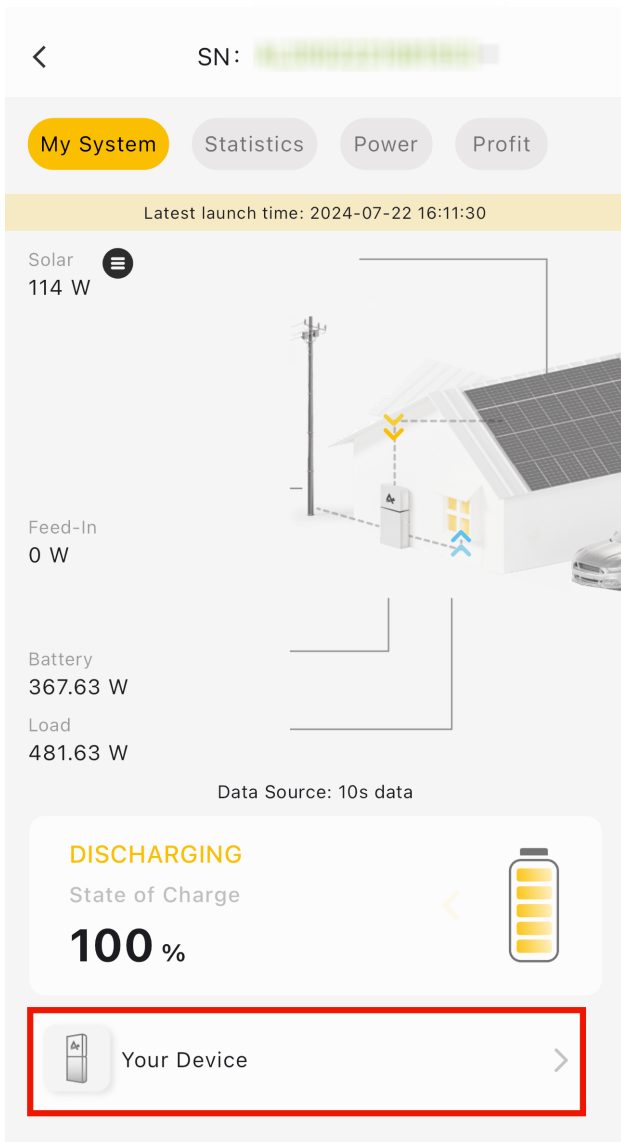

**Step2**

Inverter Information	
Model	[REDACTED]
PV Installed Capacity [kWp]	0
Rated Output Power [kW]	5
Inverter Sn	[REDACTED]
Energy Storage Inverter PV Capacity (kWp)	5
Safety Regulations	AS4777. 2:2020
Regional application standard	Australia A
Volt-Watt Response Mode	Enable
VW1	253V
VW2	260V
Volt-Var Response Mode	Enable
VV1	207 V
VV2	220 V

## 9.4. Installing New System and Settings on the APP

### 9.4.1. Download and Install the APP

Download and install the APP by scanning the QR code.



### 9.4.2. Register as an Installer

If you don't have an installer account, please register first.

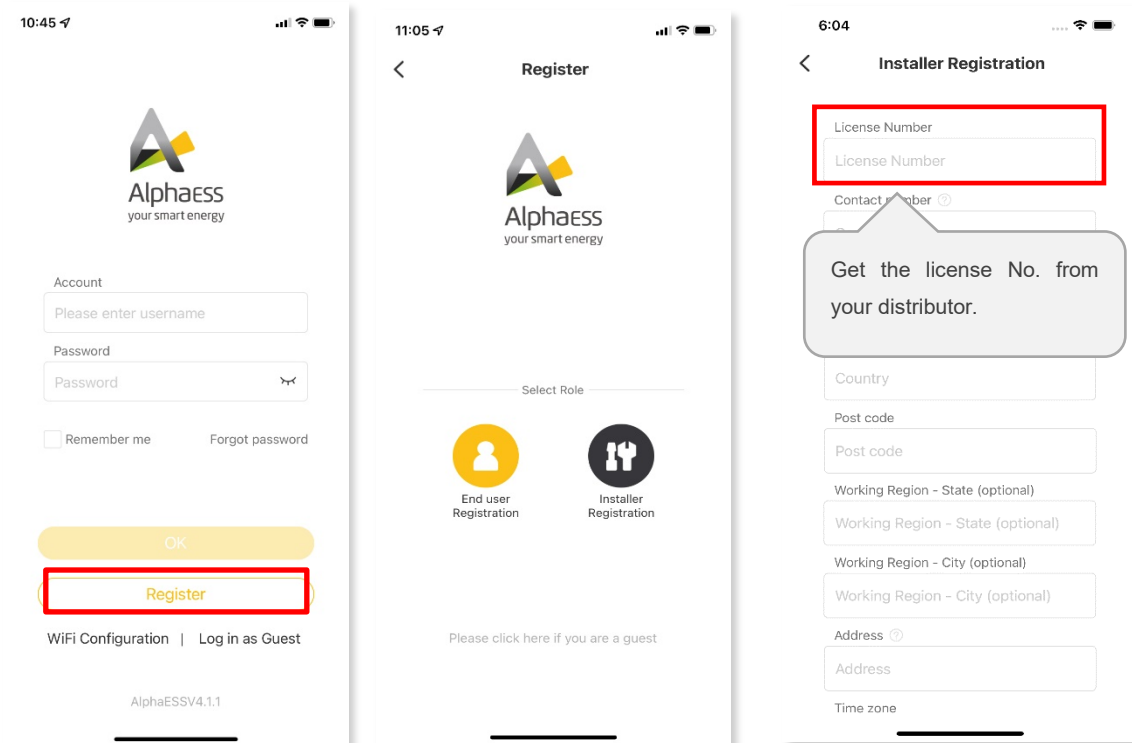

If you already have an installer account, please log in directly.

### 9.4.3. Install New System

If you have “installed” the new system already or want to install it later, please directly to the Section 9.3 WiFi Module Configuration and Parameter Settings. If not, you can “Install New System” first.

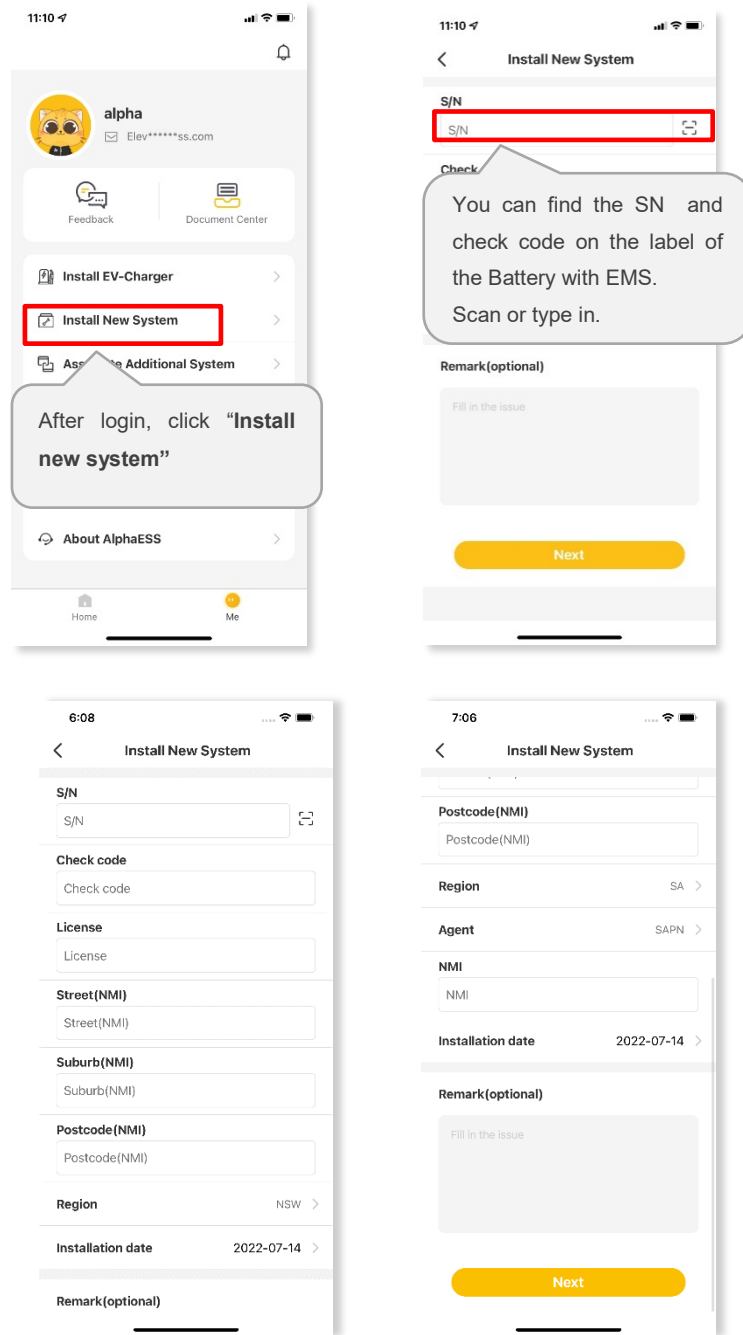

#### Australian Installer

Please enter your installer account and click “Install New System” to bind the system to your account and set the system.

Enter S/N, check code, license, create time, customer full name, contact number, address, and click the save button. If you are an Australian installer, you will need to fill in the Street (NMI), Suburb (NMI) and Postcode (NMI) fields and add a new Region field, which has six fixed options (NSW, QLD, VIC, SA, TAS, WA). If SA is selected for Region, two more fields are added which are Agent and NMI.

Fields that are not marked "optional" need to be filled in.

Click "Next" and go to Section 9.3 if the WiFi has not been configured.

## 9.5. Check the Running State

If you have completed commissioning as described in section 9.3.2, please ignore this section.

You can also commission the system after WiFi configuration.

Please make sure the PV switch and battery breakers and all the breakers connecting to the product are on.

### 9.5.1. Check the Charging Function of the Product

To make sure the system is installed and operating correctly, please set the system to "Charging/Discharging Setting" by following the instructions below.

#### Step1

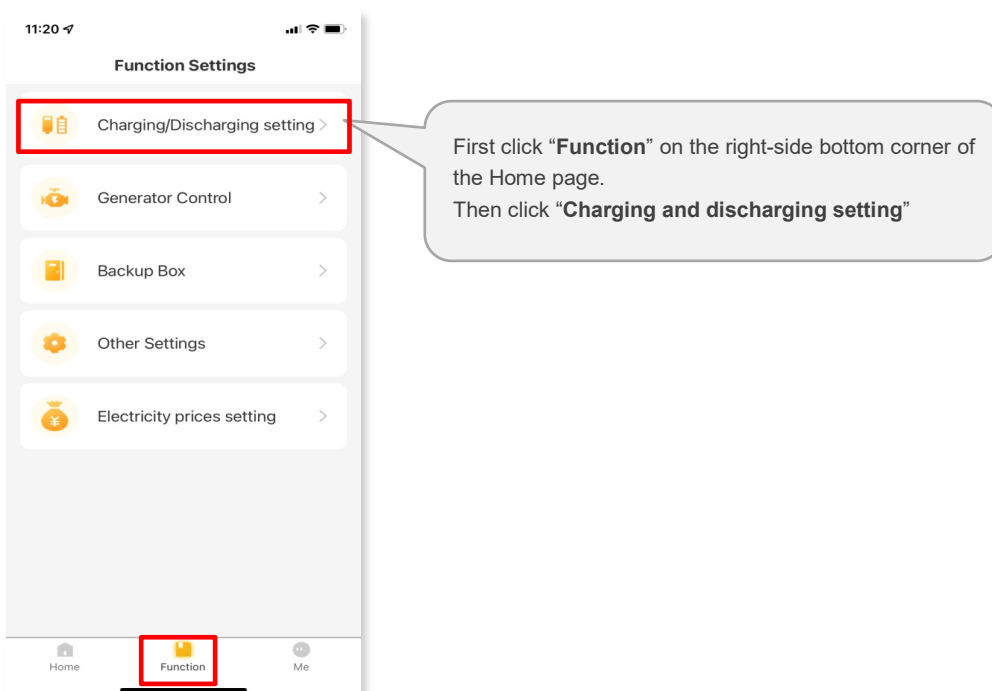

Step2

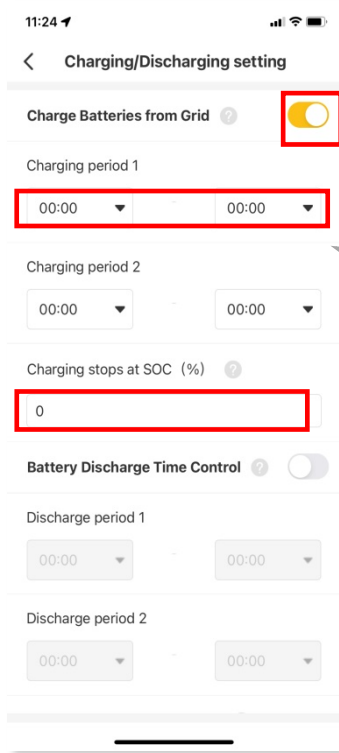

Select "ON" to Charge Batteries from Grid"

please set the "Charging period 1" for the time and the SOC would be 100 under this operation.

Step3



The relative value should be like this:  $Load = PV \pm GRID - Battery$   
 Battery should be in **charging** status. **PV arrow** should be as the picture shows.  $\pm$ :  $>>$ absorbing from grid: +;  $<<$  feed-in to grid:-  
 If not correct, please check the CT or meter installed direction of both grid and PV side

- Check the running status of the system in "Step 3".
- If the operation is normal as described in "Step3", please remember to deactivate the "Charging/Discharging Setting" by clicking "OFF" and save the changes.



### 9.5.2. Check the PV Generation and Discharging Function of the Product

**This chapter is only suitable for SMILE-S5.**

**Step1:** Please switch off the PV switch on the energy storage inverter and the AC breaker on the PV inverter if there is any. Switch on some larger loads to see the battery discharging status.



The relative value should be like this:  
Load = GRID + Battery

**Step 2:** Please switch on the PV switch on the energy storage inverter and the AC breaker on the PV inverter if there is any. Check the running status of the system.

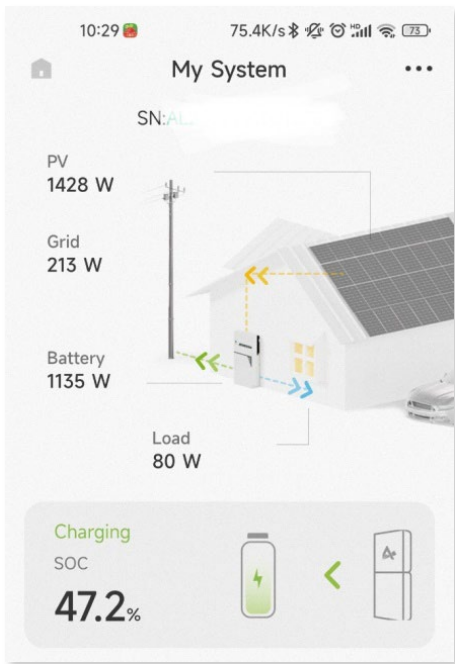

The relative value should be like this:  
Load = PV ± GRID ± Battery  
±: charging: - ; discharging: +  
PV arrow should be as the picture shows.  
±: >>absorbing from grid: +;  
<< feed-in to grid:-  
If not correct, please check the CT or meter installed direction on PV side

### 9.5.3. Check the UPS State of the Product

- Please connect an essential electrical appliance to the socket of backup load. Or switch on an essential electrical appliance already connected on the backup load port of the energy storage inverter.
- Switch on the AC breaker on the backup port of the energy storage inverter.
- Switch off the external AC breaker between the grid and the energy storage inverter.
- The product will enter the UPS mode at once.
- If the electrical appliance on backup side can work normally, it means that the wiring of the backup has been connected correctly.

 **NOTICE**

During commissioning, if the LED indicators on the display panel of the inverter or the battery pack show red, please refer to chapter troubleshooting.

#### 9.5.3.1 Switch on all of the Breakers.

Please don't forget to switch on all of the breakers.

## 9.6. Instruct the End User to Install the APP

Please make sure that your end user has downloaded the APP and registered the account correctly, and added the system SN.

## 10. Maintenance and Troubleshooting

### 10.1. Routine Maintenance

Normally, the energy storage system need no maintenance or calibration.

However, in order to maintain the accuracy of the SOC, it is recommended to perform a full charge calibration for SOC (charging battery until the charging power is 0) on the battery at regular intervals (such as two weeks).

Disconnect the energy storage system from all power sources before cleaning. Clean the housing, cover and display with a soft cloth.

To ensure that the energy storage system can operate properly in the long term, you are advised to perform routine maintenance on it as described in this chapter.

#### Maintenance checklist

Check Item	Acceptance Criteria	Maintenance Interval
Product cleanliness	The heatsink at the back of the product are free from obstacles or dust.	Semiannually or once per year
Product visible damage	The product are not damaged or deformed.	Semiannually
Product running status	<ol style="list-style-type: none"> <li>1. The product operate with no abnormal sound.</li> <li>2. All parameters of the product are correctly set. Perform this check when the product is running.</li> </ol>	Semiannually
Electrical connections	<ol style="list-style-type: none"> <li>1. Cables are securely connected.</li> <li>2. Cables are intact, and in particular, the cable jackets touching the metallic surface are not scratched.</li> <li>3. Unused cable glands are blocked by rubber sealing which are secured by pressure caps.</li> </ol>	The first maintenance 6 months after the initial commissioning. And then make it semiannually or once per year.



#### CAUTION

##### **Risk of burns due to hot heatsink and housing the inverter**

The heatsink and housing of can get hot during operation.

- During operation, do not touch any parts other than the cover.
- Wait approx. 30 minutes before cleaning until the heatsink has cooled down.

## 10.2. Troubleshooting

### 10.2.1. Inverter Error Troubleshooting

Error No.	Error description	Solution
100000	Grid_OVP	1. Check whether Grid is abnormal. 2. Confirm whether the grid cable connection is normal. 3. Restart inverter and check whether the fault is existing.
100001	Grid_UVP	
100002	Grid_OFP	
100003	Grid_UFP	
100005	BUS_OVP1	1. Restart inverter and check whether the fault is existing.
100006	BUS_OVP2	
100007	Insulation_fault	1. Check whether PV cable connection is reliable. 2. Check whether PV cable is damaged.
100008	GFCI_fault	1. Restart the inverter to see if the fault stills exists. If it still exists, please call the service center.
100009	Leakage current test failure	
100010	Grid_relay_fault	
100011	Over_Temperature	1. Check whether the environment around inverter is with poor heat dissipation. 2. Confirm whether inverter installation meet the installation requirements.
100014	M_S_com_fault	Restart the inverter and check whether the fault is existing.
100033	BAT1_HW_OCP	1. Check whether Backup load is overload. 2. Restart inverter and confirm whether the fault is existing.
100038	Output_DC_over_current	Restart system and check whether the fault is existing.
100043	Output_overload	1. Check whether backup load is overload. 2. Restart inverter and confirm whether the fault is existing.
100044	APU_UVP	Restart the inverter and check whether the fault is existing.
100046	DC_Input_Disturbance	
100047	Grid disturbance	1. Check whether grid is abnormal. 2. Confirm connection of gird cable is normal.
100048	Grid_unbalance	
100049	Frequency_jitter	

100050	Grid_overcurrent	3. Restart inverter and check whether the fault is existing.
100051	Grid_current_track_fault	Restart inverter and check whether the fault is existing.
100052	Backup_ovp	1. Check whether backup cable connection is normal. 2. Restart inverter and confirm whether the fault is existing.
100053	Dc_bus_unbalancevolt	Switch off the PV switch & all AC and BAT circuit breakers in the energy storage system, then restart it as chapter 8.1 Powering on the Product and check whether the fault is existing.
100054	Dc_bus_undervolt	
100055	Dc_bus_unbalancevolt2	
100056	IGBT_over_current	Switch off the PV switch & all AC and BAT circuit breakers in the energy storage system, then restart it as chapter 8.1 Powering on the Product and check whether the fault is existing.
100057	Grid_disturbance2	1. Confirm whether grid is distorted severely. 2. Check whether PV cable connection is reliable.
100058	AFCI_check_protect	1. Check whether PV cable connection is reliable. 2. Check whether PV cable is damaged.
100059	Grid_current_sampling_abnormal	1. Confirm whether grid is distorted severely. 2. Check whether PV cable connection is reliable.
100060	Dsp_selfcheck	Restart inverter and check whether the fault is existing.
100061	Grid_short_time_over_current	1. Confirm whether grid is distorted severely. 2. Check whether PV cable connection is reliable.
100062	Bat_overnvolt_hardware_fault	1. Check whether battery breaker has tripped off. 2. Check whether battery operation is normal.

1	NET fault	<p>NET connection fault</p> <ol style="list-style-type: none"> <li>1. Restart the system and check whether the fault can be cleared.</li> <li>2. If the fault can't be cleared, please contact the customer service center for further check.</li> </ol>
2	RTC fault	<p>Time clock chip fault</p> <ol style="list-style-type: none"> <li>1. Restart the system and check whether the fault can be cleared.</li> <li>2. If the fault can't be cleared, please contact the customer service center for further check.</li> </ol>
3	EEPROM fault	<p>EEPROM fault</p> <ol style="list-style-type: none"> <li>1. Restart the system and check whether the fault can be cleared.</li> <li>2. If the fault can't be cleared, please contact the customer service center for further check.</li> </ol>
4	Inverter lost	<p>Inverter communication lost</p> <ol style="list-style-type: none"> <li>1. Restart the system and check whether the fault can be cleared.</li> <li>2. Contact the customer service to remotely update the inverter EMS and DSP program, after that confirm whether the fault continues.</li> <li>3. If the fault can't be cleared, please contact the customer service center for further check.</li> </ol>
5	Grid meter lost	<p>Grid side meter lose</p> <ol style="list-style-type: none"> <li>1. Check whether the system configuration parameters are correct and whether the meter is used on the grid side</li> <li>2. Check whether the communication cable of the grid meter is connected correctly (RS485: 3A6B).</li> <li>3. Check whether the communication configuration parameters of the grid meter is correct (communication address and baud rate).</li> <li>4. If the fault can't be cleared, please contact the customer service center for further check.</li> </ol>









6	PV meter lost	<p>PV inverter side meter lose</p> <ol style="list-style-type: none"> <li>1. Check whether the system configuration parameters are correct and whether the meter is used at the PV inverter side</li> <li>2. Check whether the communication configuration parameters of the meter of PV inverter side is correct (communication address and baud rate). (RS485: 3A6B)。</li> <li>3. Check whether the communication configuration parameters of the meter of PV inverter side is correct (communication address and baud rate).</li> <li>4. If the fault can't be cleared, please contact the customer service center for further check.</li> </ol>
7	BMS lost	<p>BMS lost</p> <ol style="list-style-type: none"> <li>1. Check whether the BMS communication connection between the battery and the inverter is normal</li> <li>2. Check if the battery is switched on</li> <li>3. If the fault can't be cleared, please contact the customer service center for further check.</li> </ol>
8	UPS Battery Volt Low	<p>Low battery voltage in UPS mode</p> <ol style="list-style-type: none"> <li>1. Use grid power to recharge the battery.</li> <li>2. Use PV power to recharge the battery.。</li> </ol>
9	Backup Overload	<p>Overload of off grid mode</p> <ol style="list-style-type: none"> <li>1. backup overload, check whether the load connected to backup terminal exceeds the limit, reduce the load, restart the inverter or wait for 5minutes to eliminate the fault automatically or press the key to eliminate it.</li> <li>2. Disconnect the backup load, restart the system, and check whether the fault is cleared. If the fault still exists, please contact the customer service center.</li> </ol>

10	INV Slave Lost	<p>Inverter slave communication lost</p> <ol style="list-style-type: none"> <li>1. Restart the system and check whether the fault can be cleared.</li> <li>2. Contact the customer service to remotely update the inverter EMS and DSP program, after that confirm whether the fault continues.</li> <li>3. If the fault can't be cleared, please contact the customer service center for further check.</li> </ol>
11	INV Master Lost	<p>Inverter master communication lost</p> <ol style="list-style-type: none"> <li>1. Restart the system and check whether the fault can be cleared.</li> <li>2. Contact the customer service to remotely update the inverter EMS and DSP program, after that confirm whether the fault continues.</li> <li>3. If the fault can't be cleared, please contact the customer service center for further check.</li> </ol>
12	Parallel Comm Error	<p>Parallel communication lost</p> <ol style="list-style-type: none"> <li>1. Check whether the system configuration parameters are correct.</li> <li>2. Check whether the communication cables of multiple inverters in parallel are set correctly</li> <li>3. If the fault can't be cleared, please contact the customer service center for further check.</li> </ol>
13	Parallel Mode Differ	<p>Parallel mode different</p> <ol style="list-style-type: none"> <li>1. Check whether the mode of multiple inverters in parallel is set correctly</li> <li>2. Restart the system and check whether the fault can be cleared.</li> <li>3. If the fault can't be cleared, please contact the customer service center for further check.</li> </ol>



14	Flash Fault	<p>Flash Fault</p> <ol style="list-style-type: none"><li>1. Restart the system and check whether the fault can be cleared.</li><li>2. If the fault can't be cleared, please contact the customer service center for further check.</li></ol>
15	SDRAM error	<p>SDRAM error</p> <ol style="list-style-type: none"><li>1. Restart the system and check whether the fault can be cleared.</li><li>2. If the fault can't be cleared, please contact the customer service center for further check.</li></ol>
16	Extension CAN error	<p>Extension CAN error</p> <ol style="list-style-type: none"><li>1. Restart the system and check whether the fault can be cleared.</li><li>2. If the fault can't be cleared, please contact the customer service center for further check.</li></ol>
17	INV type not specified	<p>Haven't select the inverter model</p> <ol style="list-style-type: none"><li>1. The inverter type of the internal program is not configured. Contact the customer service for remote configuration.</li></ol>









### 10.2.2. Battery Protection Description

Display Mode	Protection Code	Display Icon	Description	Troubleshooting
<b>Green LEDs flicker once every 3S.</b>	1		Temperature difference	Wait for automatic recovery. In case the problem persists for a long time, call for service.
	3		High temperature	Stop discharging and charging until this state eliminate and wait for the temperature to drop.
	4		Low-temperature discharge	Stop discharging until this state eliminate and wait for the temperature to rise.
	5		Overcurrent charge	Wait for automated recovery. If the problem is not be solved yet, please call service center.
	6		Overcurrent discharge	
	8		Cell overvoltage	
	9		Cell under voltage	Stop discharging and call service immediately.
	11		Low-temperature charge	Stop discharging until this state eliminate and wait for the temperature to rise.

 **NOTE**

In the case of work mode, if the protection code 9 appears, please press the power button of the battery 5 times within 10 seconds, the BMS will be forced to turn on the MOSFET of discharge so that the inverter can detect the battery open voltage and charge the battery.

### 10.2.3. Battery Error Description

Display Mode	Error Code	Display Icon	Description	Troubleshooting
<b>Red LEDs flash once every 3S.</b>	Error 01		Temperature sensor failure	Please restart the battery. If the problem is not resolved, please call for service.
	Error 05		MOSFET error	
	Error 06		Circuit breaker open	Switch on circuit breaker after powering off the battery.
	Error 08		LMU disconnect (slave)	Reconnect the BMS communication cable.
	Error 09		SN missing	Call for service.
	Error 10		LMU disconnect (master)	Reconnect the BMS communication cable.
	Error 11		Software version inconsistent	Call for service.
	Error 12		Multi master	After switching off the battery system, please restart all batteries within 30s.
	Error 13		MOS overtemperature	Please first switch off the battery and then switch on the battery after about 2 hours.

## 11. Uninstallation & Return

### 11.1. Removing the Product

#### Procedure

- **Step 1:** Power off the product by following instructions in Chapter **8.2 Powering Off the Product**.
- **Step 2:** Disconnect all cables from the product, including communication cables, PV power cables, battery power cables, AC cables, and PE cables.
- **Step 3:** Remove the WiFi module.
- **Step 4:** Remove the product from the wall bracket.  
Remove the expandable battery packs from the wall bracket.
- **Step 5:** Remove the wall brackets.

### 11.2. Packing the Product

If the original packaging is available, put the product inside it and then seal it using adhesive tape.

If the original packaging is not available, put the product inside a suitable cardboard box and seal it properly.

### 11.3. Disposing of the Product

- If the product service life expires, dispose of it according to the local disposal rules for electrical equipment and electronic component waste.
- Dispose of the packaging and replaced parts according to the rules at the installation site where the device is installed.
- Do not dispose the product with normal domestic waste.



## 12. Specification

### 12.1. General overview

#### SMILE-S5/B5

Model	SMILE-S5*	SMILE-B5**
<b>System Specification</b>		
Nominal Output Power	5000 W /VA	5000 W /VA
Capacity Range	5.04 ~ 30.24 kWh (95% DoD)	
Battery Chemistry	LFP (LiFePO4)	
IP Protection	IP65 (Outdoor)	
System Dimension (W x D x H)	640 x 250 x 695 mm	
System Weight	70 kg	68 kg
Warranty	5 Year Product Warranty, 10 Year Performance Warranty***	
<b>BESS Model</b>	SMILE-S5/B5 II( 115 kg/113 kg; 650 x 250 x 1040 mm; 10.08 kWh): SMILE-S5/B5+SMILE-BAT-5Px1	
	SMILE-S5/B5 III( 160 kg/158 kg; 650 x 250 x 1385 mm; 15.12 kWh): SMILE-S5/B5+SMILE-BAT-5Px2	
	SMILE-S5/B5 IV( 205 kg/203 kg; 650 x 250 x 1730 mm; 20.16 kWh): SMILE-S5/B5+SMILE-BAT-5Px3	
	SMILE-S5/B5 V( 250 kg/248 kg; 650 x 250 x 2075 mm; 25.20 kWh): SMILE-S5/B5+SMILE-BAT-5Px4	
	SMILE-S5/B5 VI( 295 kg/293 kg; 650 x 250 x 2420 mm; 30.24 kWh): SMILE-S5/B5+SMILE-BAT-5Px5	
<b>Inverter Technical Specification</b>		
Coupling	Hybrid	AC
Max. Input DC Voltage	600V	NA
Max. PV Input Power	8000 W	NA
Max. PV Input Current	15 A / 15 A	NA
Start-up voltage	120 V	NA
Minimum operating voltage	90 V	NA
MPPT No/Strings Per MPPT	2/1	NA
MPPT Voltage Range	90 ~ 520 V	NA
Max. PV Short-circuit Current	22.5 / 22.5 A	NA
Max. Charging/Discharging Current	100 A	100 A
Max. Charging/Discharging Power	5000 W	5000 W
Rated Frequency	50 / 60 Hz	
Rated Voltage	230 V	
Rated. AC Output Current	21.7 A	21.7 A
Max. AC Input Current	33 A	33 A
UPS Power	5000 W/VA	
Efficiency	96.7%	96.5%
Humidity	0~95% (No Condensing)	
Dimension (W x D x H)	530 x 250 x 350 mm	
Inverter Weight	25 kg	23 kg
Operating Temperature Range	-25 to +60 °C (derating above 45 °C )	
Active anti-islanding method	Active frequency shifting	
Inverter Topology	Non-isolated	
Safety	IEC 62109, IEC 62477	
EMC	EN61000-6-1/-2/-3/-4	
Grid Regulation	AS4777.2	
<b>Battery Technical Specification</b>		
Module Mode	SMILE-BAT-5P	
Module Capacity	5.04 kWh	
Usable Capacity	4.79 kWh	
Dimension (W x D x H)	650 x 250 x 345 mm	
Inverter Weight	45 kg	
Depth of Discharge (DoD)	95%	
Nominal Voltage	48 V	
Max. Charging/Discharging Current	52.5 A	
Operating Temperature Range	-10°C ~ 50°C****	
Cycle Life	6000	
External Battery Expansion	1 ~ 5 in parallel	

\* The system will be named as SMILE-S5, SMILE S5 II, SMILE-S5 III, SMILE-S5 IV, SMILE-S5 V, SMILE-S5 VI with 1~6 batteries modules.

\*\* The system will be named as SMILE-B5, SMILE B5 II, SMILE-B5 III, SMILE-B5 IV, SMILE-B5 V, SMILE-B5 VI with 1~6 batteries modules.

\*\*\* The precondition of the valid Performance Warranty shall be that: The ambient temperature during the operation of the Products shall not fall below -10 °C or exceed 50 °C, and the Throughput Energy per kWh Usable Capacity is less than 3.12MWh.

\*\*\*\* When the ambient temperature is too low or too high, the performance of battery may be limited.

## 12. Specification

### 12.2. Datasheet of SMILE-S5/B5

Model	SMILE-S5*	SMILE-B5**
<b>Input DC (PV side)</b>		
Recommended max. PV power	8 kW	
Max. PV input voltage	600V	
Rated voltage	330V	
MPPT Full Power Voltage Range	300-450V	
Start-up voltage	120V	
MPPT voltage range	90~520V	
Max. input current Per MPPT	15A/15A	
Max. short circuit current per MPPT	22.5/22.5A	
Backfeed Current	0A	
MPPT number	2	
Max input strings number per MPPT	1 / 1	
Weight(Inverter)	25 kg	23 kg
Dimension (W*H*D)	530*350*250 mm	
<b>Battery (Inverter side)</b>		
Battery type	Li-ion	
Battery voltage range	42 ~ 54 V	
Maximum charge/ discharge power	5 kW	
Maximum charge/ discharge current	100 A / 100 A	
Max. short-circuit current	120 A / 120 A	
Communication	CAN	
<b>Output AC (Back-up side)</b>		
Rated output power	5 kW	
Max. apparent output power	5 kVA	
Back-up switch time	<20 ms	
Rated output voltage	L/N/PE, 230 V	
Rated frequency	50 Hz	
Maximum output fault current	32 A 10 us	
Current (inrush)	0 A	
Maximum overcurrent protection	22 A	
Maximum output current	22 A	
Rated output current	21.7 A	
THDv(@linear load)	2%	
<b>Input AC (Grid side)</b>		
Rated input voltage	L/N/PE, 230 V	
Rated frequency	50 Hz	
Rated Input power	7 kW	
Max. input current	33 A	
Max. short-circuit current	40 A	

<b>Output AC (Grid side)</b>	
Rated output power	5 kW
Max. apparent output power	5 kVA
Rated grid voltage	L/N/PE, 230 V
Rated grid frequency	50 Hz
Maximum output fault current	32A 10us
Current (inrush)	32A 10us
Maximum overcurrent protection	22 A
Maximum output current	22 A
Rating grid output current	21.7 A
Power factor	>0.99 (0.8 leading - 0.8 lagging)
THDi	< 2%
Protection class	I
Overvoltage category	III
<b>Efficiency (Inverter side)</b>	
Max efficiency	>97.5%
EU efficiency	>96.8%
<b>Protection (Inverter side)</b>	
PV reverse-polarity protection	Integrated
Anti-Islanding protection	Integrated
Insulation resistance Detection	Integrated
Residual current monitoring unit	Integrated
Output overcurrent protection	Integrated
Output short circuit protection	Integrated
Output overvoltage protection	Integrated
Battery reverse protection	Integrated
Battery breaker	Integrated
<b>Features</b>	
AC connection	Plug in connector
PV connection	Plug in connector, MC4
BAT connection	Screw terminal block
Communication	LAN, WiFi (optional)
Warranty	5 years standard
<b>General Data</b>	
Display	LED
Dimensions (W*H*D)	640*695*250 mm
Weight	SMILE-S5: 70 kg; SMILE-B5: 68 kg
Topology	Transformerless
Operation temperature range	-25 ~ +60 °C
Ingress protection	IP65
Relative humidity	0 ~ 100%
Noise emission	<35 dB(A) @1m
Cooling Concept	Natural convection
Max. operation altitude	3000 m

\*The specific model and designation of the SMILE-S5 series can be found in Appendix 3.

\* \*The specific model and designation of the SMILE-B5 series can be found in Appendix 3.

### 12.3. Datasheet of Battery SMILE-5P

Model	Battery pack (SMILE-BAT-5P)
Battery type	LFP (LiFePO4)
Weight	45 kg
Dimension (W*H*D)	640*345*250 mm
Ingress protection	IP65
Energy capacity	5.04 kWh
Usable capacity	4.79 kWh
DoD	95%
Nominal voltage	48 V
Operating voltage range	45 ~ 54 V
Internal resistance	≤ 20 mΩ
Max. Charging /discharging current *	60 A
Operating temperature range	Charge: 0<T<50°C / Discharge: -10<T<50°C
Monitoring parameters	System voltage, current, cell voltage, cell temperature, PCBA temperature
BMS communication	CAN and RS485 compatible
<b>System</b>	
Safety	IEC62040-1, IEC62109-1/-2, AS3100
EMC standard	EN61000-6-1/-2/-3/-4
Warranty	5 Year product warranty, 10 Year performance warranty ( for battery )
Transportation	UN38.3

\* Max. charge/discharge current derating will occur related to temperature and SOC.



## Appendix 1: System Overview

01

SMILE-S5/B5 System Wiring Diagram with CT

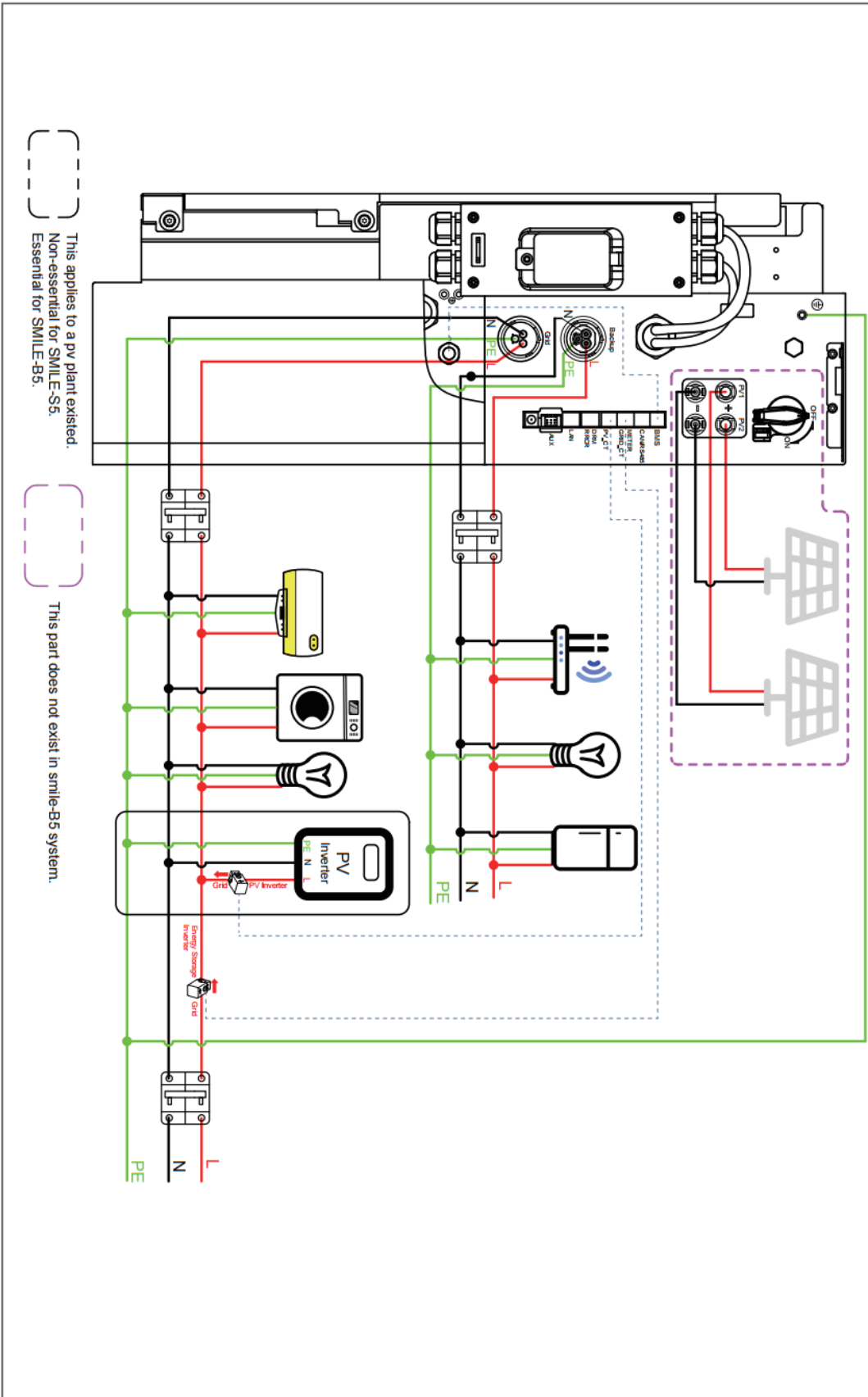

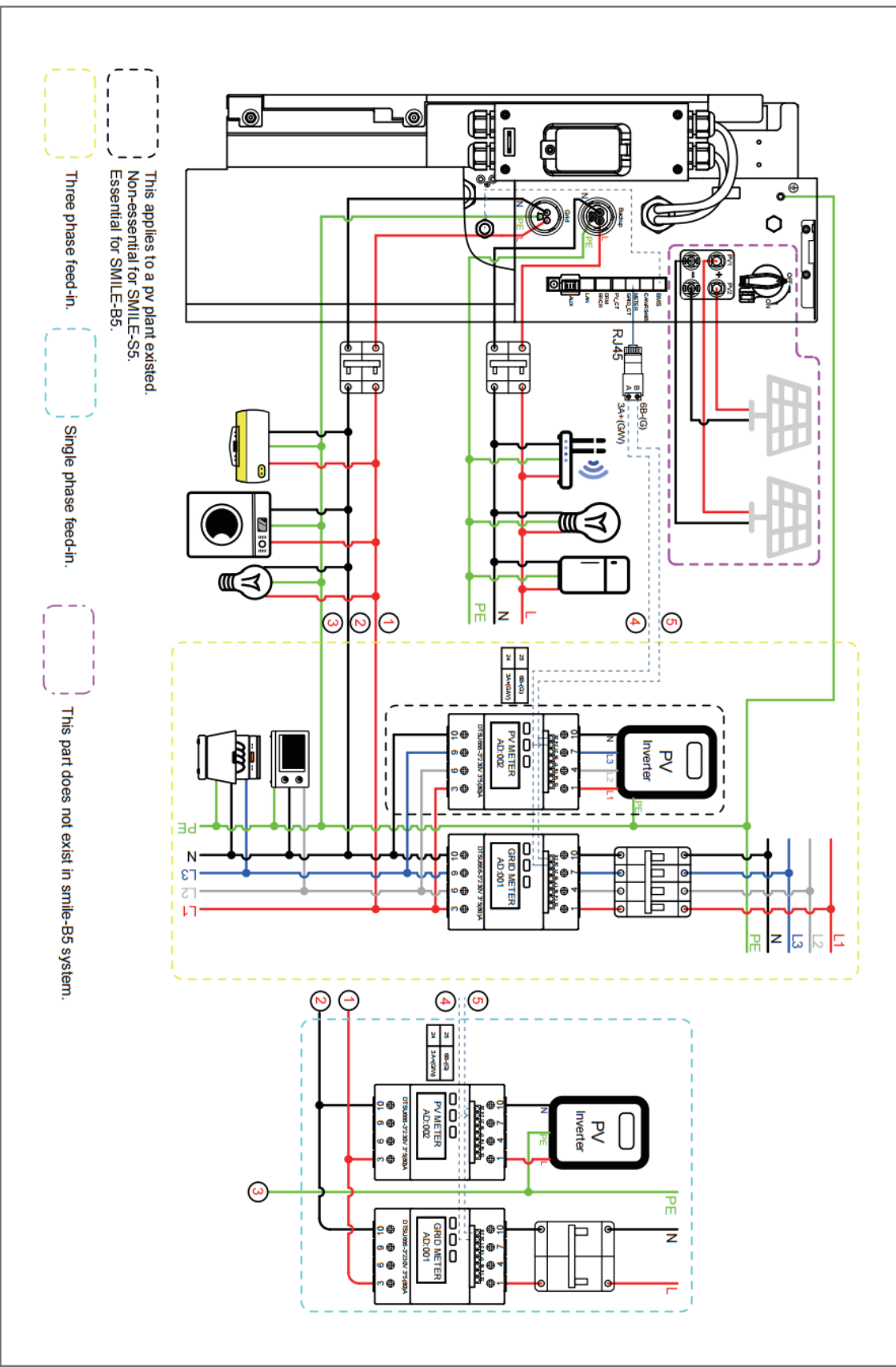

This applies to a pv plant existed. Non-essential for SMILE-S5. Essential for SMILE-B5.

Three phase feed-in.

Single phase feed-in.

This part does not exist in smile-B5 system.

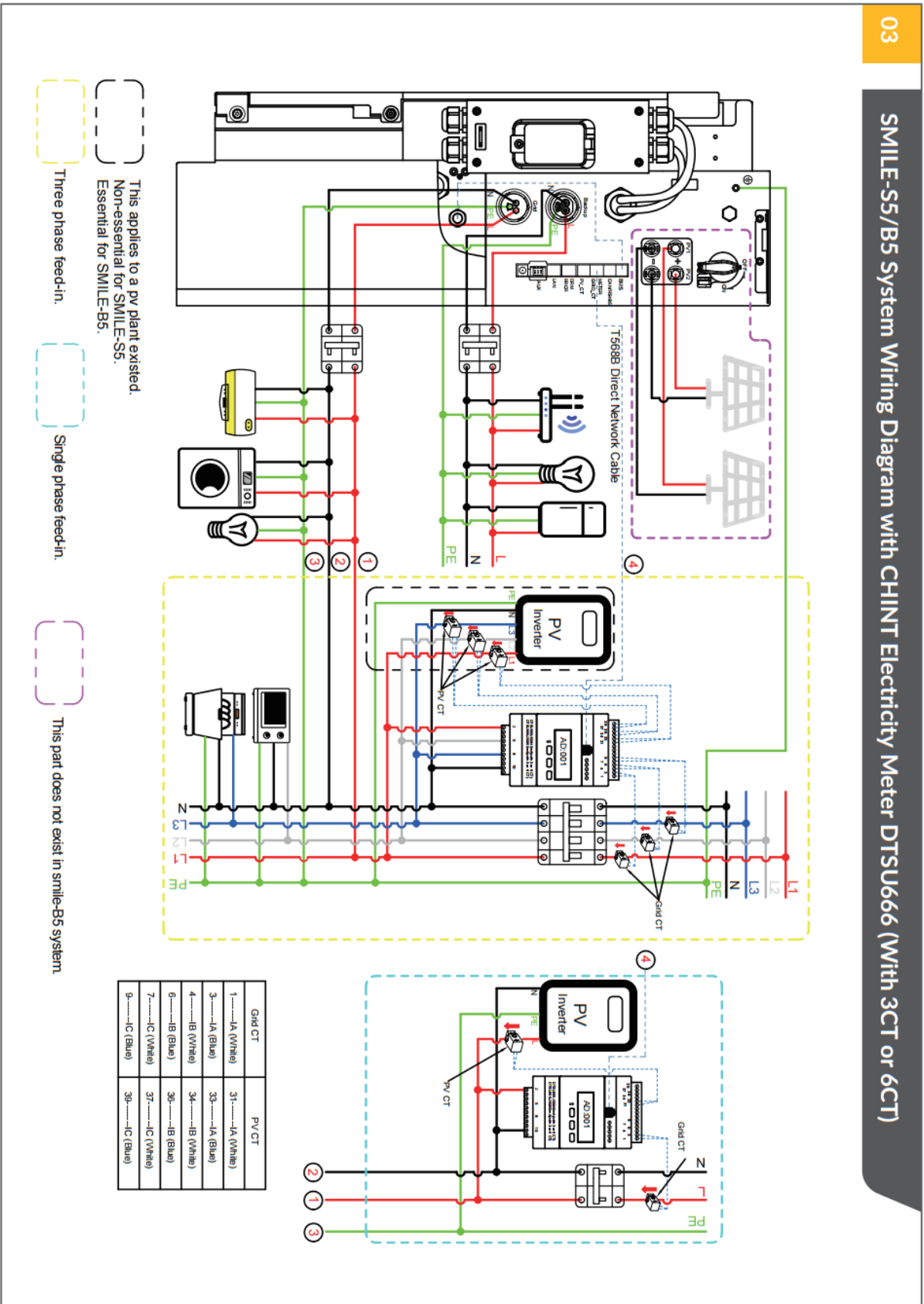

SMILE-S5/B5 System Wiring Diagram with CT

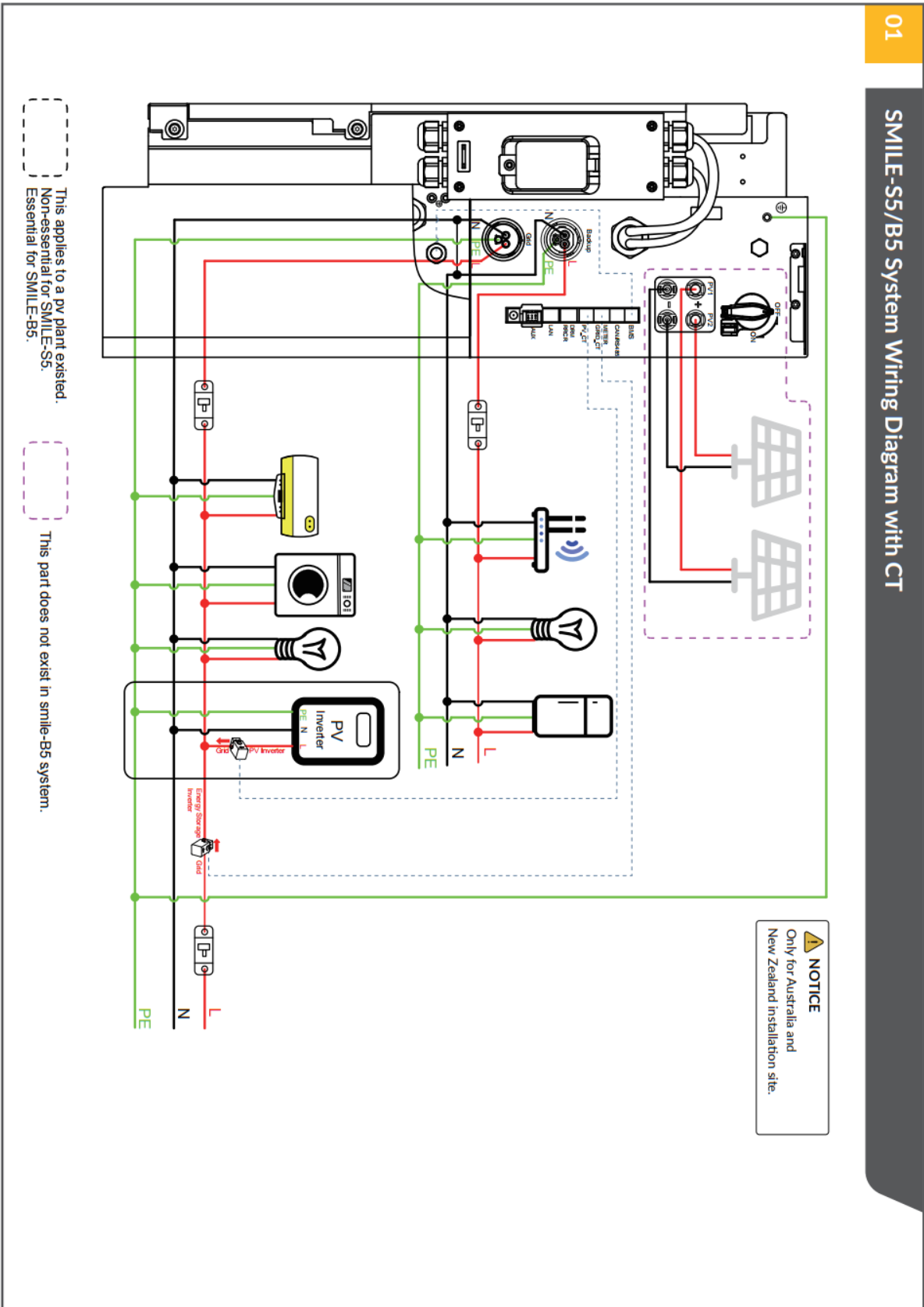

This applies to a pv plant existed. Non-essential for SMILE-S5. Essential for SMILE-B5.

This part does not exist in smile-B5 system.

**NOTICE**  
Only for Australia and New Zealand installation site.

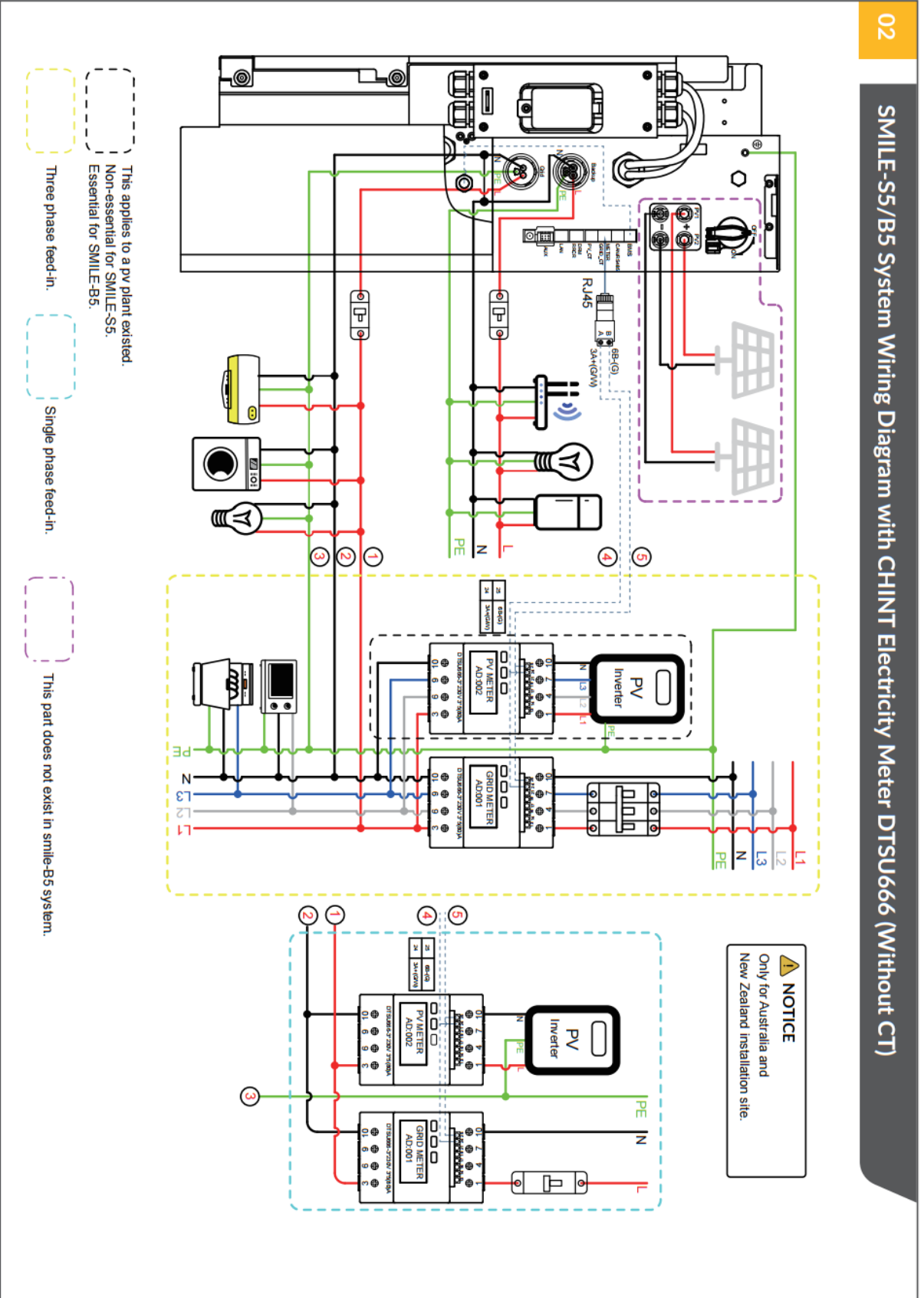

SMILE-S5/B5 System Wiring Diagram with CHINT Electricity Meter DTU666 (With 3CT or 6CT)

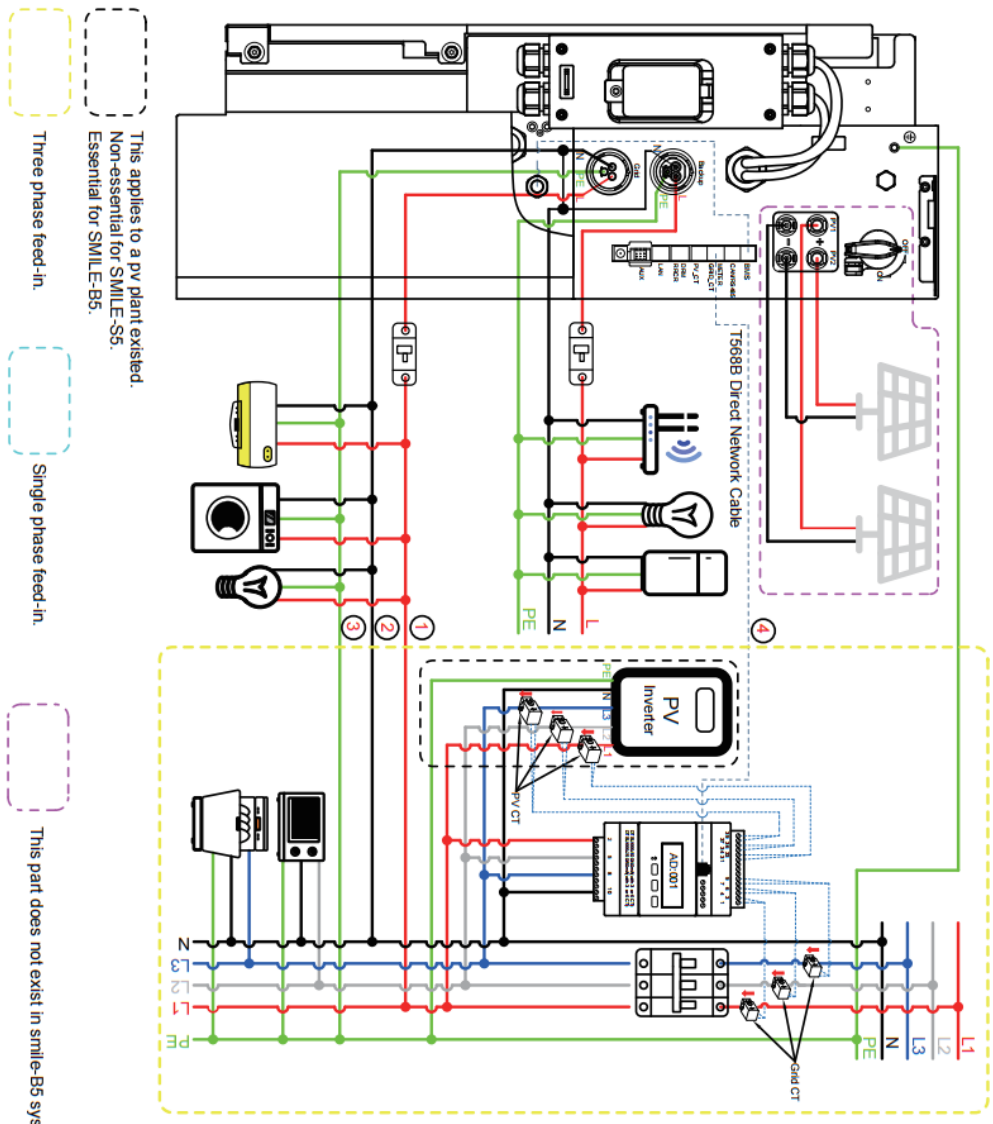

This applies to a PV plant existed. Non-essential for SMILE-S5. Essential for SMILE-B5.

Three phase feed-in.

Single phase feed-in.

This part does not exist in smile-B5 system.

**NOTICE**  
 Only for Australia and New Zealand installation site.

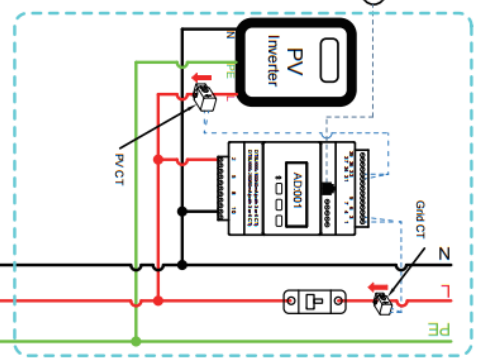

Gnd CT	PV CT
1.....1A (White)	31.....1A (White)
3.....1A (Blue)	33.....1A (Blue)
4.....1B (White)	34.....1B (White)
6.....1B (Blue)	36.....1B (Blue)
7.....1C (White)	37.....1C (White)
9.....1C (Blue)	39.....1C (Blue)

## Appendix 2: Regional Application Standard

Please check with your local grid company and choose the correspond Regional Application Standard, the power quality modes Volt-VAR and Volt-Watt will be running automatically. (Only for regions with AS/NZW 4777.2 safety regulations).

Regional application Standard	Electric Company
Australia A	N/A
Australia B	N/A
Australia C	N/A
New Zealand	N/A
Vector	New Zealand Vector

## Appendix 3: Nomenclature of Model

Complete designation	Designation in this document
SMILE-S5	
SMILE-S5 I	5kW Hybrid system with 5.04kWh battery
SMILE-S5 II	5kW Hybrid system with 10.08kWh battery
SMILE-S5 III	5kW Hybrid system with 15.12kWh battery
SMILE-S5 IV	5kW Hybrid system with 20.16kWh battery
SMILE-S5 V	5kW Hybrid system with 25.20kWh battery
SMILE-S5 VI	5kW Hybrid system with 30.24kWh battery
SMILE-B5	
SMILE-B5 I	5kW AC coupled system with 5.04kWh battery
SMILE-B5 II	5kW AC coupled system with 10.08kWh battery
SMILE-B5 III	5kW AC coupled system with 15.12kWh battery
SMILE-B5 IV	5kW AC coupled system with 20.16kWh battery
SMILE-B5 V	5kW AC coupled system with 25.20kWh battery
SMILE-B5 VI	5kW AC coupled system with 30.24kWh battery



## Appendix 4: Earth Fault

If the system occurs an earth fault, the user will receive a mail like this to remind them check the grounding status.

---

Dear User,

Your system has an earth fault, the details are as follows:

SN	Status	Error Code	Update Time
AL7001000000001	Earth Fault	EMS:18	<a href="#">8/5/2024 4:31:27 PM</a>

Please contact your installer company to correct these faults.

This email is automatically sent by the system, please do not reply directly.

Sincerely,  
Alpha ESS Co., Ltd.

---





 @AlphaEnergyStorageSystem  @AlphaESS  @alpha\_ess  @AlphaESS  www.alphaess.com

---

### Alpha ESS Co., Ltd.

 +86 513 8060 6891  
 info@alpha-ess.com  
 www.alphaess.com  
 No. 1086 Bihua Road, Tongzhou District, Nantong City, Jiangsu Province, China

### Alpha ESS Suzhou Co., Ltd.





 +86 512 6828 7609  
 info@alpha-ess.com  
 www.alphaess.com  
 Building 10-A, Canal Town Industrial Park, 99 Taihu E Rd, Wuzhong District, Suzhou 215000

---

### Alpha ESS Europe GmbH



 +49 610 3459 1601  
 europe@alpha-ess.de  
 www.alphaess.de  
 Paul-Ehrlich-Straße 1a, D-63225 Langen, Hessen

### Alpha ESS Italy S.r.l.



 +39 339 462 4288  
 info@alpha-ess.it  
 www.alphaess.com  
 Via Don Minzoni, 17, Calenzano Firenze 50041

---

### Alpha ESS Australia Pty. Ltd.



 +61 402 500 520  
 info@alpha-ess.com  
 www.alphaess.com

### Alpha ESS Korea Co., Ltd



 info@alpha-ess.com  
 2F, 19-4, Nohyeong 11-gil, Jeju-si, Jeju-do, Republic of Korea

---

### Alpha ESS UK Co., Ltd



 +44 145 354 5222  
 info@alpha-ess.com  
 Drake House, Long Street, Dursley, gl11 4hh

### Alpha ESS International Pte. Ltd.

 +65 6513 1125 / +65 6513 1126  
 Singapore@alpha-ess.com  
 2 Corporation Road #01-06A Corporation Place Singapore 618494

---

### Alpha ESS USA, Inc.

 +1 408 368 7828  
 usa@alpha-ess.com  
 Unit 5 2180 S Ivanhoe St, Denver, CO 80222